



LPS 1261, Cert No 566/01



G419028



Rapidrop® Braided Flexible Sprinkler Hose

Model: RD-SMB

General Description

Rapidrop flexible sprinkler hoses are typically used as an alternative to traditional hard pipe arm overs and are particularly suited for use in suspended ceiling applications.

The Rapidrop flexible sprinkler hose is an adjustable, braided, helical corrugated stainless steel connection that removes the need for cutting, threading, welding or precise measurements. The benefits are considerable for the installer and the building owner.

Features

- Reduced install time
- Easily formed by hand
- Requires only normal hand tools
- Centre of tile and correct vertical position first time every time
- Self-supporting so no intermediate supports are required on lengths below 1.6 metres
- Full system pressure test can be accommodated at first fix stage, no need to drain down for second fix, just depressurise, therefore no system refill or second pressure test
- Sprinkler heads even when operated at maximum pressure have no adverse effects upon the ceiling suspension system

A large range of ceiling support brackets are available to suit different ceiling systems including lift out tile, fixed board and many other types. Brackets to accommodate all sprinkler types such as concealed, flush pendent and pendent heads are also available. With numerous inlet, outlet and bracket options, Rapidrop flexible sprinkler hoses are supplied in kit form containing only the specific components required.

Approvals

FM, LPCB, VdS, CE

Material Specification

Description	Material
Flexible hose	Stainless Steel 304
Braiding	Stainless Steel 304
Nut	Carbon Steel, Zinc Plated
Isolation ring	Nylon 66
Seal	NBR
Outlet Reducer	Carbon Steel, Zinc Plated
Inlet Nipple	Carbon Steel, Zinc Plated
Centre Bracket A	Carbon Steel, Zinc Plated
Side Bracket B	Carbon Steel, Zinc Plated
Square Bar	Carbon Steel, Zinc Plated



Technical Details

Max. Working Pressure	12bar / 175 psi (FM) 16bar / 232 psi (LPCB, VdS)
Max. Ambient Temperature	107°C / 225°F
Min. Ambient Temperature	5°C / 41°F
Min. Bend Radius of Flexible Hose	165mm / 6½" (FM) 75mm / 3" (LPCB, VdS)
Connection to Branch Line (Inlet)	1" BSPT / 1" NPT 1¼" BSPT / 1¼" NPT
Connection to the Sprinkler (Outlet)	½" BSPT / ½" NPT ¾" BSPT / ¾" NPT Straight or 90° Elbow
Max K-Factor	K200 (K14) (FM) K80 (K5.6) (LPCB*, **) K115 (K8.0) (VdS) *LPCB LPS1261 iss3.0 limits all flexible sprinkler connections to K80 (K5.6)

**LPCB allows installation in wet pipe systems only.

NOTE: The flexible stainless steel hose should not be bent within 65mm (2½") of the connection nut at both ends.



Data Sheet 3.11

Issue J



LPS 1261, Cert No 566/01



G419028



Rapidrop® Braided Flexible Sprinkler Hose

Model: RD-SMB

Pressure Loss Data

FM

Model	Hose Assembly length	Minimum Bend Radius	Maximum Number of 90° Bends	Maximum Working Pressure	Equivalent Length of 1 in. Schedule 40 Pipe			
					1/2" outlet K80 (K5.6)	3/4" outlet K115 (K8.0)	3/4" outlet K160 (K11.2)	3/4" outlet K200 (K14)
	mm(inch)	mm (inch)	bar (psi)	Straight outlet m (ft) 90° Elbow outlet m (ft)				
RD-SMB-01	780 (31)	165 (6 1/2)	1	12 (175)	7 (23) 8.3 (27.2)	5.1 (16.8) 6.9 (22.8)	5.4 (17.7) 6.9 (22.6)	5.6 (18.4) 6.7 (21.9)
RD-SMB-02	1000 (39)	165 (6 1/2)	3	12 (175)	9.6 (31.4) 10.2 (33.7)	7.9 (25.8) 8.1 (26.8)	7.9 (25.8) 7.9 (26.2)	7.9 (25.9) 7.9 (25.9)
RD-SMB-03	1220 (48)	165 (6 1/2)	3	12 (175)	12.1 (39.8) 12.2 (40)	10.6 (34.8) 9.4 (30.9)	10.2 (33.5) 9.1 (29.9)	10.2 (33.4) 9.1 (30)
RD-SMB-04	1540 (60)	165 (6 1/2)	4	12 (175)	13.9 (45.6) 15.1 (49.6)	12.6 (41.4) 12.5 (40.9)	12.4 (40.7) 12.2 (40.1)	12.4 (40.8) 12.5 (41.1)
RD-SMB-05	1830 (72)	165 (6 1/2)	4	12 (175)	15.5 (50.9) 17.8 (58.4)	14.4 (47.3) 15.2 (49.9)	14.4 (47.2) 15 (49.4)	14.5 (47.6) 15.6 (51.2)

Pressure Loss Data

LPCB

Model	Hose Assembly length	Minimum Bend Radius	Maximum Number of 90° Bends	Maximum Working Pressure	Equivalent Length of DN 25 BS EN 10225 Pipe
					1/2" outlet, Straight or 90° Elbow K80 (K5.6)
	mm (inch)	mm (inch)	bar (psi)	m (ft)	
RD-SMB-01	780/(31)	75 (3)	1	16 (232)	2.2 /(7.2)
RD-SMB-02	1000/(39)	75 (3)	3	16 (232)	5.3/(17.4)
RD-SMB-03	1220/(48)	75 (3)	3	16 (232)	6.3/(20.7)
RD-SMB-04	1540/(60)	75 (3)	3	16 (232)	7.1/(23.2)
RD-SMB-05	1830/(72)	75 (3)	3	16 (232)	7.7 /(25.2)

Pressure Loss Data

VdS

Model	Hose Assembly length	Minimum Bend Radius	Maximum Number of 90° Bends	Maximum Working Pressure	Equivalent Length of DN 25 BS EN 10225 Pipe
					1/2" & 3/4" outlet Straight or 90° Elbow K57(K4.0), K80(K5.6), K115(K8.0)
	mm (inch)	mm (inch)	bar (psi)	m (ft)	
RD-SMB-01	780/(31)	75 (3)	1	16 (232)	1.56/(5.1)
RD-SMB-02	1000/(39)	75 (3)	3	16 (232)	2.0/(6.56)
RD-SMB-03	1220/(48)	75 (3)	3	16 (232)	2.44/(8.0)
RD-SMB-04	1540/(60)	75 (3)	4	16 (232)	3.08/(10.1)
RD-SMB-05	1830/(72)	75 (3)	4	16 (232)	3.66/(12.0)

DS: 3.11
Issue J
18/11/2024
© 2024 Rapidrop

Rapidrop Global Ltd
T: +44 (0) 1733 847 510 F: +44 (0) 1733 553 958
e: rapidrop@rapidrop.com
w: www.rapidrop.com



Rapidrop® Braided Flexible Sprinkler Hose Model: RD-SMB

Important Installation Information

- Rapidrop Flexible Sprinkler Hose must only be installed by an appropriately qualified person in accordance with the requirements of the local authority having jurisdiction. Deviations from these standards will void any warranty.
- Alterations to Rapidrop products will void any warranty.
- Rapidrop Flexible Sprinkler Hose, brackets and fittings must not be intermixed with other manufacturer's products.
- The flexible stainless steel hose should only be installed inside buildings and protected from freezing temperatures.
- LPCB allows installation of flexible hoses only in wet pipe systems. They should not be installed in dry, alternate or deluge systems.
- The flexible hose should NOT be installed through heating ducts and fire compartments, therefore not to be used with penetration seals, fire stopping cavity barriers, and anything further indicated by approval bodies and sprinkler rules.
- In the event that a flexible sprinkler hose is installed and the ceiling structure to be completed at a later date, it is the responsibility of the installer to ensure that the flexible sprinkler hose is suitably supported in order to reduce the bending moment on the top joint and give adequate protection from other trades.
- It is the responsibility of the system designer to verify suitability for use of chemical exposure, water additives, temperature, UV exposure. If in doubt contact the manufacturer.
- System designer or responsible person should check with the Rapidrop sales representative that the flexible hose meets the local water regulations.
- The flexible hose should not be bent or manipulated when pressurized.
- Hose connections should not be tightened or adjusted when system is pressurised.
- Flexible stainless steel hose and fittings have limited flexibility and are intended only to be installed with bends at their respective minimum bend radius.
- Hose connections should not be tightened by rotating the nipple or reducer as it may result in damage to the seal.
- DO NOT join 2 or more flexible hoses together.

- The flexible stainless steel hose should not be bent within 65 mm (2 1/2 inches) of its connection nuts



- The owner is responsible for maintaining the fire protection system in proper operating condition.
- Flexible hose to be inspected and maintained during routine sprinkler system inspections by a qualified inspection service in accordance with national codes/requirements.

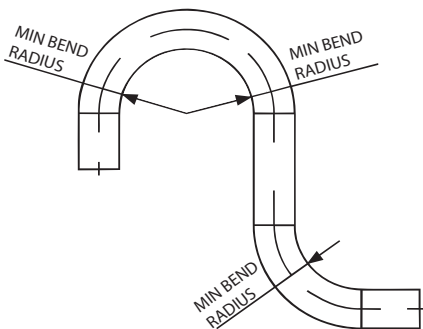

Rapidrop® Braided Flexible Sprinkler Hose Model: RD-SMB

Installation of A2 type centre bracket with metal ceiling suspension system

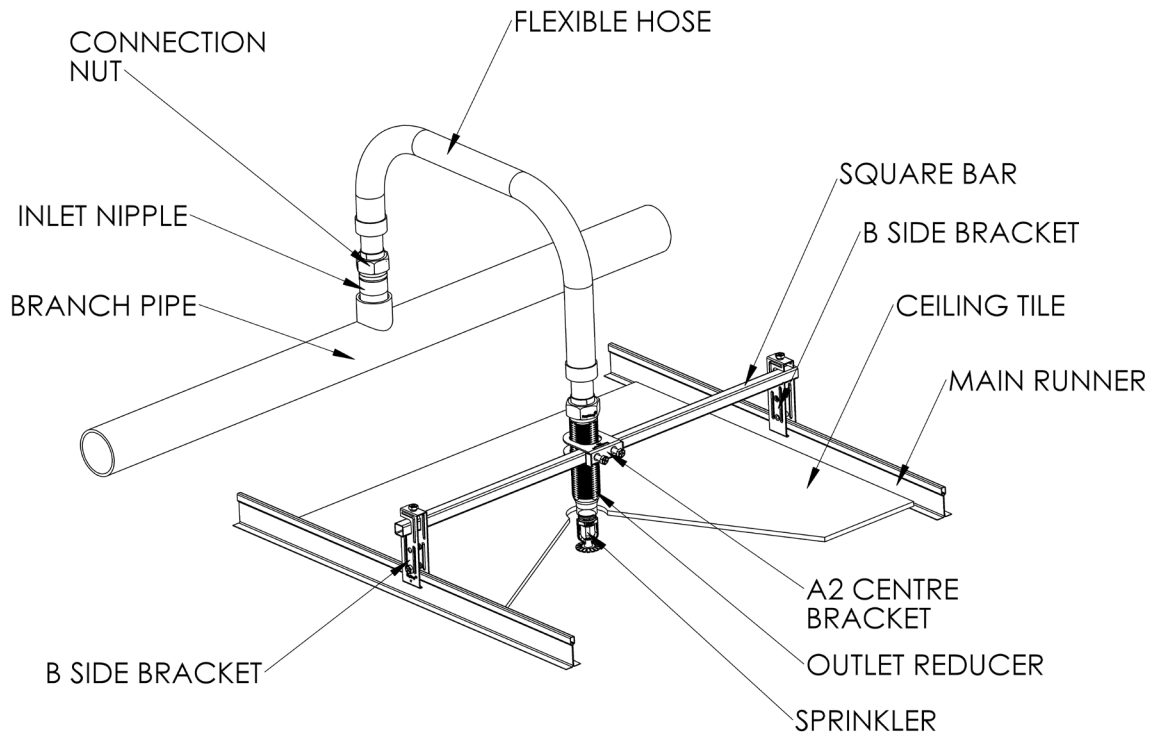

1. Install the Inlet Nipple in the Branch Pipe outlet using the normal sealing and tightening methods for connecting pipe threads. Tighten firmly with a pipe wrench for leak proof connection.



2. Remove plastic Protecting Cap from one end of the flexible hose, check that the black rubber seal is in place and connect the Outlet Reducer (M33 x 1.5 thread end) to that end. To prevent reducer from turning, securely hold in place whilst tightening the hose nut. Tighten to a torque of 20 Nm/15 ft-lbs. Do not exceed the specified torque. Do not use joint compound or PTFE tape on the M33 threads.





Rapidrop® Braided Flexible Sprinkler Hose Model: RD-SMB

3. Remove plastic Protecting Cap from the other end of the flexible hose, check that the black rubber Seal is in place and connect that end to the inlet nipple on the range pipe and tighten the nut to a torque of 20 Nm/15 ft-lbs).



4. Bend the flexible hose to achieve the required routing maintaining the minimum bend radius and position the reducer for sprinkler location. When bending the hose allow 65mm of straight hose from the nut, ensure there are no kinks.

5. Attach side B Brackets to the main runners of the suspended ceiling using screws provided. Lightly tighten side screws to hold brackets on the ceiling grid rails.

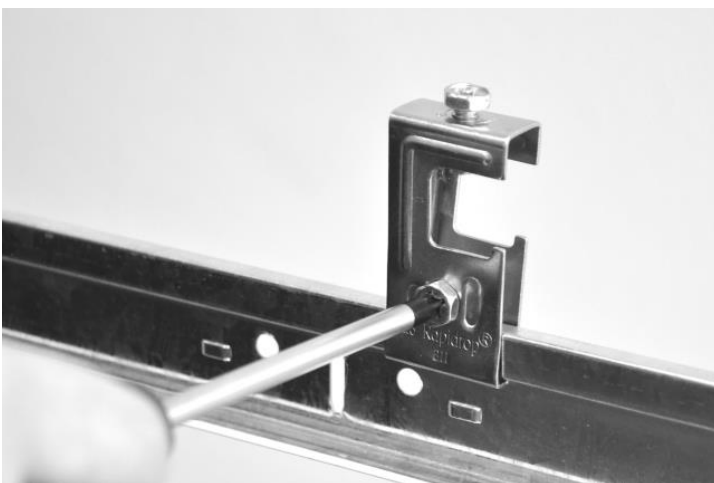

6. Attach square bar to the side B brackets, tighten the top screws.

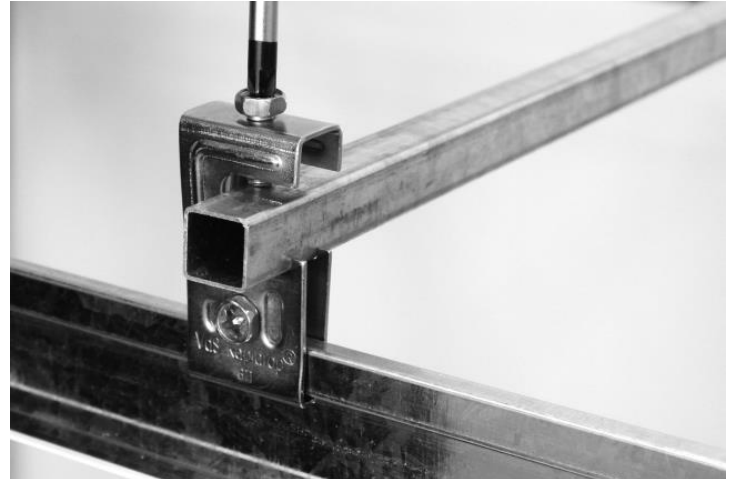

7. Slide A2 type centre bracket onto the square bar, mount the outlet reducer through the centre bracket and lightly tighten the nut. Adjust location of the centre bracket and the side brackets until desired location of the outlet reducer is achieved. Firmly secure the side brackets by tightening the screws to a torque of 5 Nm/4 ft-lbs.



Rapidrop® Braided Flexible Sprinkler Hose Model: RD-SMB

8. Apply a non-hardening pipe joint compound or PTFE tape to the male thread of the sprinkler head and install in the Outlet Reducer according to the sprinkler head manufacturer's instructions, using the wrench supplied by the manufacturer.



When installing the sprinkler head with a two piece escutcheon, the inner piece should be mounted on the thread of the sprinkler head before attaching to the reducer.

9. Adjust height of the Outlet Reducer until desired location of the sprinkler is achieved. Firmly secure the Centre Bracket by tightening the screws to a torque of 5 Nm/4 ft-lbs).

10. After installation is complete, test the sprinkler system for leaks in accordance with Authority Having Jurisdiction. It is advised to not leave the sprinkler system drained for long periods.

The Rapidrop Flexible Hose assembly must be fixed to full height cross tees of the suspended ceiling system using support bar and brackets supplied. The Rapidrop Flexible Hose end B Brackets are not compatible with reduced height or lightweight cross tees.

If there are no full height cross tees available, Rapidrop Flexible Hose assembly must be fixed to the Main Runners of the suspended ceiling system. As the Main Runners are usually spaced at 1,200mm this method requires a longer support bar which is available. Various types of B Brackets are available to suit the suspended ceiling Cross Tees and Main Runners, with heights to suit both spray pendent sprinklers with escutcheons and concealed sprinklers.

Do not over tighten bracket screws.

Rapidrop® Braided Flexible Sprinkler Hose Model: RD-SMB

Installation of ARF02 Quick Fit bracket with metal ceiling suspension system

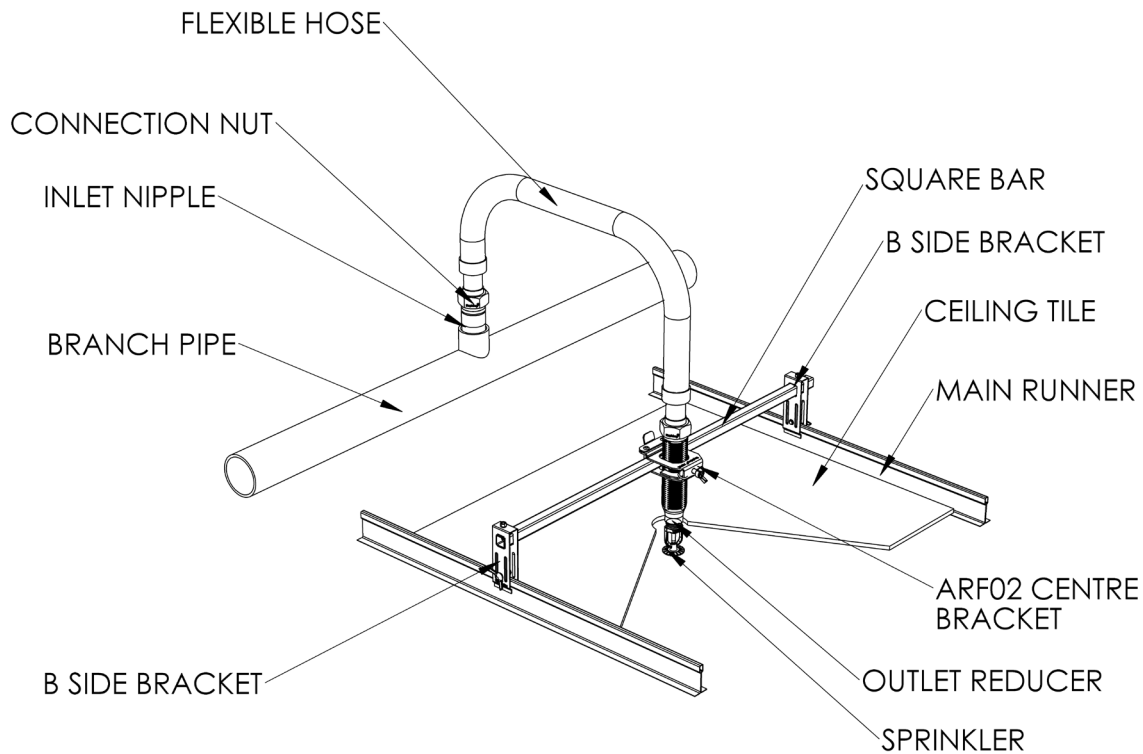

1. Install the Inlet Nipple in the branch pipe outlet using the normal sealing and tightening methods for connecting pipe threads. Tighten firmly with a pipe wrench for leak proof connection.



2. Remove plastic Protecting Cap from one end of the flexible hose, check that the black rubber seal is in place and connect the Outlet Reducer (M33 x 1.5 thread end) to that end. To prevent reducer from turning, securely hold in place whilst tightening the hose nut. Tighten to a torque of 20 Nm/15 ft-lbs. Do not exceed the specified torque. Do not use joint compound or PTFE tape on the M33 threads.





Rapidrop® Braided Flexible Sprinkler Hose Model: RD-SMB

3. Connect Centre Bracket ARF02 to the Outlet Reducer with the tab facing up and lightly tighten the wing nut.

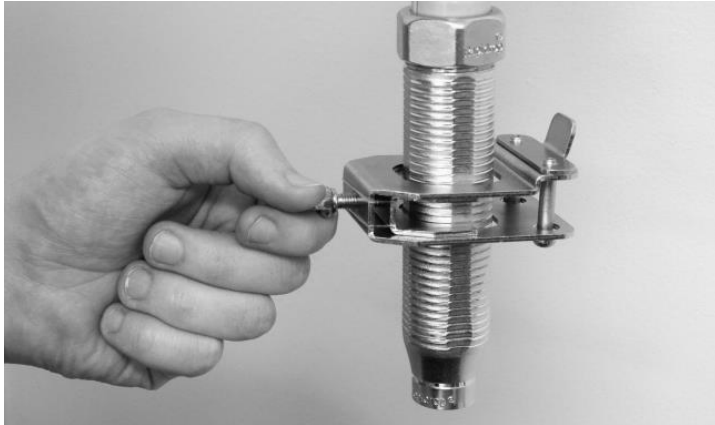

4. Apply a non-hardening pipe joint compound or PTFE tape to the male thread of the sprinkler head and install in the Outlet Reducer according to the sprinkler head manufacturer's instructions, using the wrench supplied by the manufacturer.



When installing the sprinkler head with a two piece escutcheon, the inner piece should be mounted on the thread of the sprinkler head before attaching to the reducer.

5. Remove plastic protecting cap from the other end of the flexible hose, check that the black rubber Seal is in place and connect that end to the inlet nipple on the range pipe and tighten the nut to a torque of 20 Nm/15 ft-lbs.



6. Bend the flexible hose to achieve the required routing maintaining the minimum bend radius and position the reducer for sprinkler location. When bending the hose allow 65mm of straight hose from the nut, ensure there are no kinks.

If assembly of the ceiling structure has not been completed it may possible to pressurise the system and perform first pressure test at this stage

7. Attach square bar with preassembled side B Brackets or optional separate square bar and B brackets to the main runners of the suspended ceiling. Lightly tighten wing screws to hold brackets on the ceiling grid rails.





Data Sheet 3.11

Issue J



LPS 1261, Cert No 566/01



G419028



Rapidrop® Braided Flexible Sprinkler Hose

Model: RD-SMB

8. Lift the tab of the ARF02 centre bracket and attach it to the square bar. Lightly tighten the wing screw.



9. Adjust height of the Outlet Reducer until desired location of the sprinkler is achieved. Firmly secure the Centre Bracket by tightening the wing screw to a torque of 5 Nm/4 ft-lbs).

10. After installation is complete, test the sprinkler system for leaks in accordance with Authority Having Jurisdiction. It is advised to not leave the sprinkler system drained for long periods.

The Rapidrop Flexible Hose assembly must be fixed to full height cross tees of the suspended ceiling system using support bar and brackets supplied. The Rapidrop Flexible Hose end B Brackets are not compatible with reduced height or lightweight cross tees.

If there are no full height cross tees available, Rapidrop Flexible Hose assembly must be fixed to the Main Runners of the suspended ceiling system. As the Main Runners are usually spaced at 1,200mm this method requires a longer support bar which is available. Various types of B Brackets are available to suit the suspended ceiling Cross Tees and Main Runners, with heights to suit both spray pendent sprinklers with escutcheons and concealed sprinklers.

Do not over tighten bracket screws.



Rapidrop® Braided Flexible Sprinkler Hose Model: RD-SMB

Installation of A1 centre bracket with metal ceiling suspension system

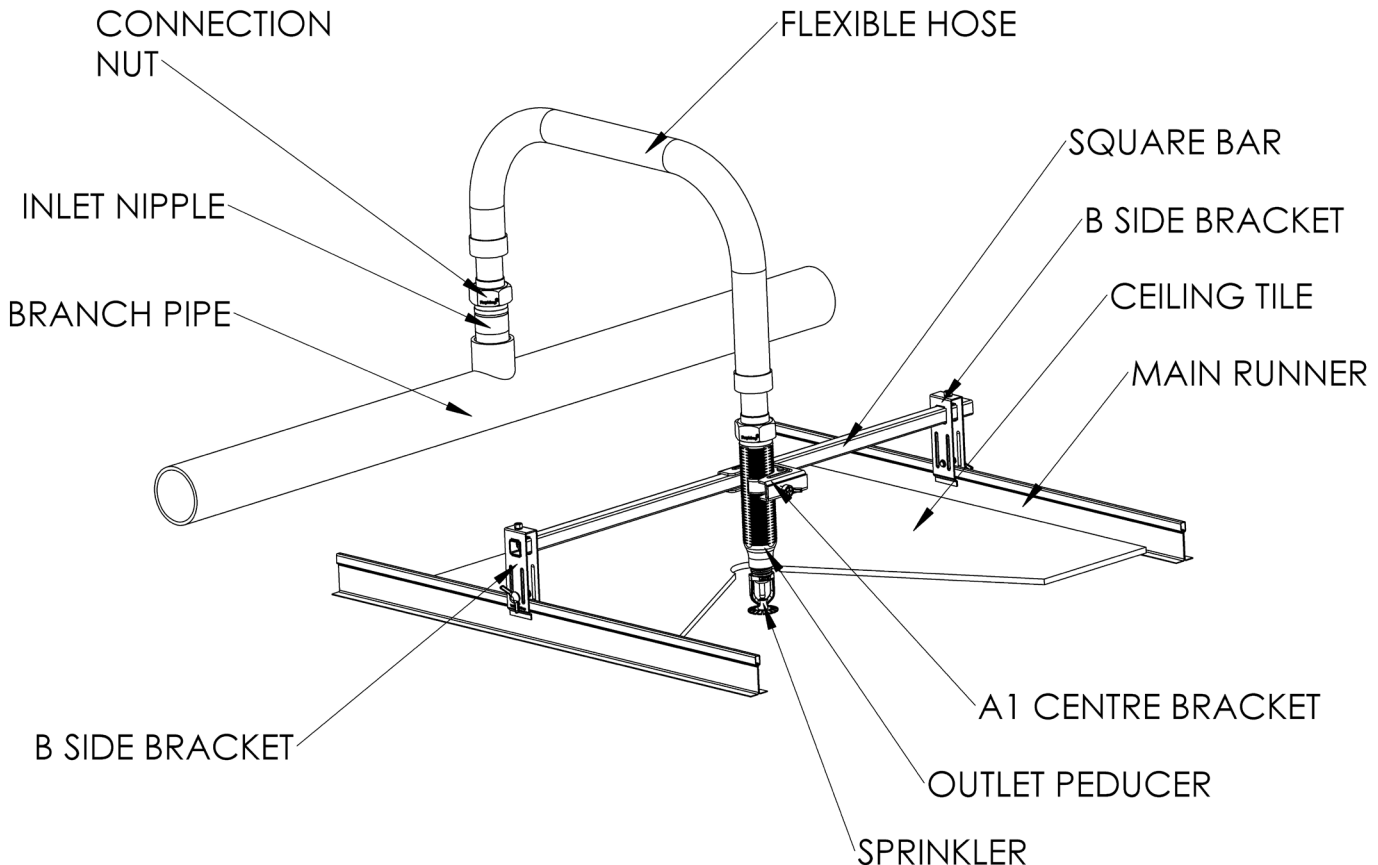

1. Install the Inlet Nipple in the branch pipe outlet using the normal sealing and tightening methods for connecting pipe threads. Tighten firmly with a pipe wrench for leak proof connection.

2. Remove plastic Protecting Cap from one end of the flexible hose, check that the black rubber Seal is in place and connect that end to the inlet nipple on the range pipe and tighten the nut to a torque of 20 Nm/15 ft-lbs).





Rapidrop® Braided Flexible Sprinkler Hose Model: RD-SMB

3. Attach side B Brackets to the main runners of the suspended ceiling using screws provided. Lightly tighten side screws to hold brackets on the ceiling grid rails.

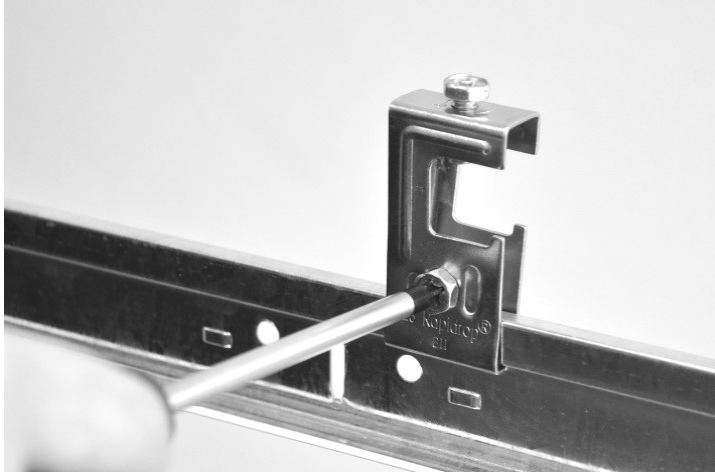

4. Slide A1 Centre Bracket onto the Square Bar.

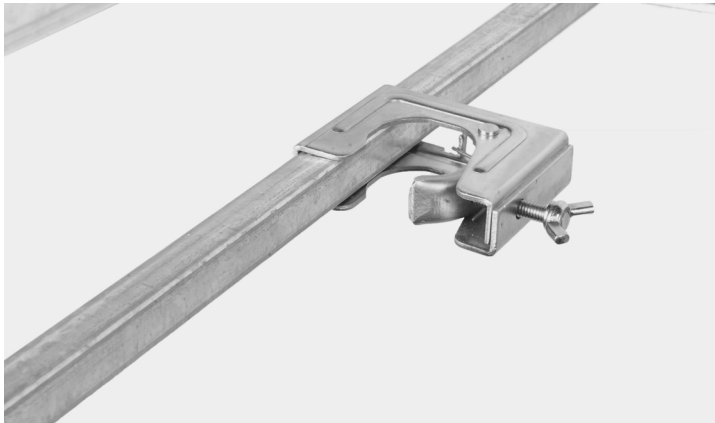

5. Attach square bar to the side B brackets, tighten the top screws.



6. Remove plastic Protecting Cap from the other end of the flexible hose, check that the black rubber seal is in place and connect the Outlet Reducer (M33 x 1.5 thread end) to that end. To prevent reducer from turning, securely hold in place whilst tightening the hose nut. Tighten to a torque of 20 Nm/15 ft-lbs. Do not exceed the specified torque.





Rapidrop® Braided Flexible Sprinkler Hose Model: RD-SMB

7. Apply a non-hardening pipe joint compound or PTFE tape to the male thread of the sprinkler head and install in the Outlet Reducer according to the sprinkler head manufacturer's instructions, using the wrench supplied by the manufacturer.

When installing the sprinkler head with a two piece escutcheon, the inner piece should be mounted on the thread of the sprinkler head before attaching to the reducer.

8. Bend the flexible hose to achieve the required routing maintaining the minimum bend radius of (inner edge) and position the reducer for sprinkler location. When bending the hose allow 65mm of straight hose from the nut, ensure there are no kinks.

9. Mount the outlet reducer through the A1 centre bracket and lightly tighten the wing bolt. Adjust location of the centre bracket and the side brackets until desired location of the outlet reducer is achieved. Firmly secure the side brackets by tightening the screws to a torque of 5 Nm/4 ft-lbs.

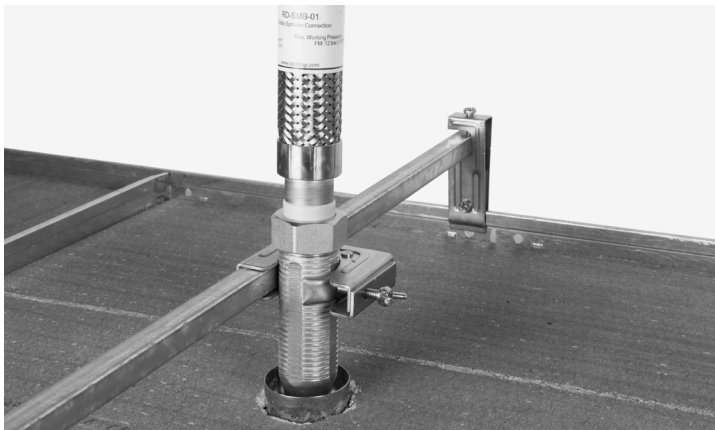

10. Adjust height of the Outlet Reducer until desired location of the sprinkler is achieved. Firmly secure the Centre Bracket by tightening the wing bolt to a torque of 5 Nm/4 ft-lbs).

The Rapidrop Flexible Hose assembly must be fixed to full height cross tees of the suspended ceiling system using support bar and brackets supplied. The Rapidrop Flexible Hose end B Brackets are not compatible with reduced height or lightweight cross tees.

If there are no full height cross tees available, Rapidrop Flexible Hose assembly must be fixed to the Main Runners of the suspended ceiling system. As the Main Runners are usually spaced at 1,200mm this method requires a longer support bar which is available. Various types of B Brackets are available to suit the suspended ceiling Cross Tees and Main Runners, with heights to suit both spray pendent sprinklers with escutcheons and concealed sprinklers.

Do not over tighten bracket screws.

Important Installation Information

- Rapidrop *Braided Flexible Sprinkler Hose* must only be installed by a competent person in accordance with requirements of the local authority having jurisdiction. Deviations from these standards will invalidate warranty.
- It is the responsibility of the installing contractor to include a copy of this document in the sprinkler system installation, operating and maintenance manual.
- Alterations to Rapidrop products will void any warranty.
- *Braided Flexible Sprinkler Hose* should be inspected and maintained during routine sprinkler system inspections by a competent person in accordance with national codes/requirements.
- Failure to follow these instructions could cause improper operation, resulting in personal injury and/or property damage.
- For further details and technical support please contact your Rapidrop sales representative.