



# Grooved Swing Check Valve Fig. 301

## General Description

Rapidrop Figure 301 is a rubber faced, grooved swing type check valve that allows water flow in one direction only. A hinged clapper remains open with water flowing in one direction, and automatically closes, with the help of an incorporated spring, when flow stops preventing backflow.

Rapidrop Figure 301 check valve features two drain plugs, one positioned before and one after the clapper to facilitate efficient maintenance and drainage. Additionally, it includes two auxiliary plugs, also located before and after the clapper, allowing for easy integration of auxiliary equipment.



## Connections

Groove to ISO 6182

## Maximum Working Pressure

17.2 bar (250 psi) FM Approved

20.7 bar (300 psi) UL Listed

25.0 bar (362 psi) VdS, LPCB & CNBOP Certificates

## Temperature Range

0°C - 80°C (32°F - 176°F)

## Coating

Fusion Bonded Epoxy Coating

In accordance with ANSI / AWWA C550 or painting upon request

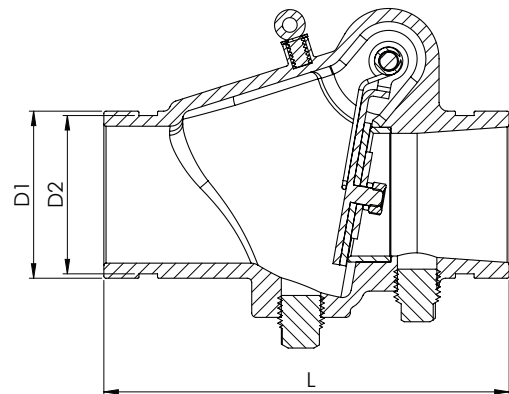

## Approvals

FM Approved, UL Listed, LPCB, VdS and CNBOP Certificates

## Dimensions

Sizes		Dimensions (mm)			Weight (kg)	Product Ordering Code	Approvals			
mm	Inch	L	D2	D1			UL	FM	LPCB / CNBOP	VdS
DN50	2"	171	57.1	60.3	3.3	RD301CV050	✓	✓	✓	✓
DN65	2 1/2"	184	69.1	73.0	3.6	RD301CV073	✓	✓	✓	X
DN65	2 1/2"	184	72.2	76.1	3.6	RD301CV065	✓	✓	✓	✓
DN80	3"	197	84.9	88.9	4.6	RD301CV080	✓	✓	✓	✓
DN100	4"	210	110.1	114.3	7.4	RD301CV100	✓	✓	✓	✓
DN125	5"	248	135.5	139.7	10.0	RD301CV139	X	X	✓	✓
DN125	5"	248	137.0	141.3	10.0	RD301CV125	X	X	✓	X
DN150	6"	324	160.9	165.1	16.1	RD301CV150	✓	✓	✓	X
DN150	6"	324	163.9	168.3	16.1	RD301CV168	✓	✓	✓	✓
DN200	8"	371	214.4	219.1	26.9	RD301CV200	✓	✓	✓	✓
DN250	10"	457	268.3	273.0	51.9	RD301CV250	✓	✓	✓	✓
DN300	12"	535	318.3	323.9	75.6	RD301CV300	✓	✓	✓	✓

# Grooved Swing Check Valve

## Fig. 301

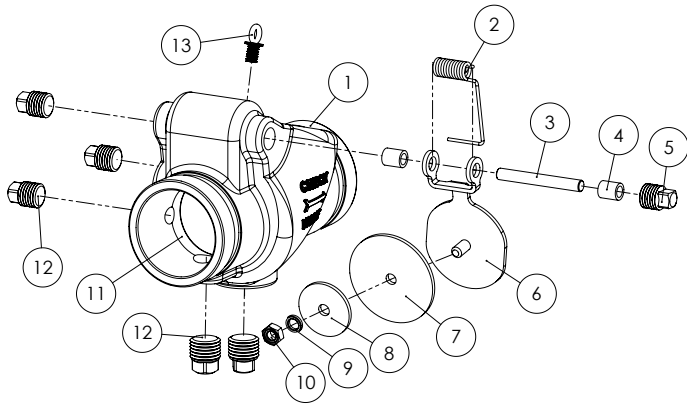

### Installation

The valve must be installed with the direction arrow on the body coincident with the direction of the flow in the pipeline. Rapidrop grooved swing check valve can be installed horizontally or vertically. For vertical pipework the flow direction should be upwards only. Large valves are provided with lifting eye bolt, which should be used to manoeuvre the valve.

**Note:** Check valves can be compromised by excessively turbulent water flow, which can lead to product damage. To minimize this risk, it's important to install check valves at a sufficient distance from sources of turbulence such as pumps, elbows, tee's, expanders, reducers, or similar components. Best practices in piping recommend placing the valve at least five times the pipe's diameter away from these components.

### Material Specification

No	Description	Material
1	Valve Body	Ductile Iron 65-45-12
2	Spring	Stainless Steel 304
3	Hinge Pin	Stainless Steel 420
4	Hinge Bushing	Brass C26800
5	Hinge Plug	Malleable Iron Zinc Plated
6	Clapper Arm	Stainless Steel 304(≤4") Ductile Iron 65-45-12 (>4")
7	Clapper Gasket	EPDM
8	Retaining Disc	Stainless Steel 304
9	Spring Washer	Stainless Steel 304
10	Nut	Stainless Steel 304
11	Seat Ring	Brass C83600
12	Drain Plug	Malleable Iron Zinc Plated
13	Eye Bolt*	Carbon Steel Zinc Plated

\*DN200 / 8" and above

### Important Installation Information

- Rapidrop Figure 301 grooved swing check valve must only be installed by a competent person in accordance with requirements of the local authority having jurisdiction. Deviations from these standards will invalidate warranty.
- It is the responsibility of the installing contractor to include a copy of this document in the sprinkler system installation, operating and maintenance manual.
- Alterations to Rapidrop products will void any warranty.
- Figure 301 grooved swing check valve should be inspected and maintained during routine sprinkler system inspections by a competent person in accordance with national codes/requirements.
- Failure to follow these instructions could cause improper operation, resulting in personal injury and/or property damage.
- For further details and technical support please contact your Rapidrop sales representative.