



Supervisory Pressure Switches Fig. RDEPS120-1 and RDEPS120-2

Important

This instruction manual contains important information about the installation and operation of supervisory pressure switches. Purchasers who install switches for use by others must leave this manual or a copy of it with the user.

Read all instructions carefully before installation, following only those instructions that apply to the model you are installing. Before installing any alarm device, be thoroughly familiar with:
NFPA 72: National Fire Alarm Code
NFPA 13: Installation of Sprinkler Systems
NFPA 25: Inspection, Testing, and Maintenance of Water-based Fire Protection Systems
NFPA 13D: Standard for 1 and 2 Family Dwellings and Manufactured Homes
NFPA 13R: Standard for Multi-family Dwellings
Other applicable NFPA standards, local codes, and the requirements of the authority having jurisdiction.
Failure to follow these directions may result in failure of the device to report an alarm condition. Rapidrop is not responsible for devices that have been improperly installed, tested, or maintained.

Caution

Do not use in potentially explosive atmospheres. Do not leave unused wires exposed.

Operation

As pressure changes, a diaphragm actuates 1 or 2 snap action switches. The pressure switch actuation is determined by adjustment settings.

Installation

1. Remove Cover: Cover is held on by two screws.
2. Mounting the Switch: The device is designed to be mounted in the upright position; side mounting is also acceptable. Locate it where vibration, shock, and mechanical loading are minimal. Refer to piping diagram above
 - a. Mount the device directly to the line via the 1/2" NPT pressure connection. The use of teflon pipe sealant tape is recommended. Be sure the fitting is tight enough to prevent leaks.
 - b. Apply tightening torque to the black plastic hex portion of the device.
3. Wire the device in accordance with the National Electrical Code. Two 7/8" diameter conduit connection holes have been provided in the mounting plate to accept standard 1/2" conduit fittings (one is removable knock-out type). If a NEMA 4/UL 4x (waterproof unit) is required, waterproof flexible metallic conduit and appropriate conduit fittings must be used. Recommended connectors are Thomas and Betts PN 5332 (180° coupling), PN 5352 (90° coupling), and PN 5262 seal ring.
4. Connect wiring to terminals (see Figure 2 and Table 1).
Adjustments to Factory Settings



Specification

Maximum Working Pressure	20.7 bar (300 psi)
Maximum Adjustment Pressure Range	0.7 to 13.8 bar (10 to 200 psi)
Differential	Approximately 0.2 bar (3 psi) @ 0.7 bar (10 psi), 0.6bar (9 psi) @ 13.8 bar (200psi)
Factory Setting	RDEPS120-1 operates at decreasing pressure at 105 psi RDEPS120-2 operates at increasing pressure at 125 psi and decreasing pressure at 105 psi
Switch Contact Ratings	RDEPS120-1: One set SPDT (Form C) RDEPS120-2: Two sets SPDT (Form C) 10.0 A, 1/2 HP @ 125/250 VAC 2.5 A @ 6/12/24 VDC
Pressure Connection	1/2" NPT male glass reinforced nylon
Operating Temperature Range	Indoor or outdoor use: -40°C to 71°C (-40°F to 160°F)
Enclosure	Rated UL 4x, NEMA 4 for indoor or outdoor use

Figure 1. Dimensions

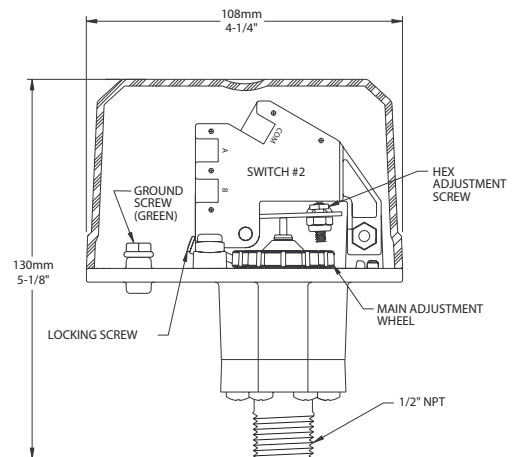

Supervisory Pressure Switches Fig. RDEPS120-1 and RDEPS120-2

Typical Sprinkler Applications

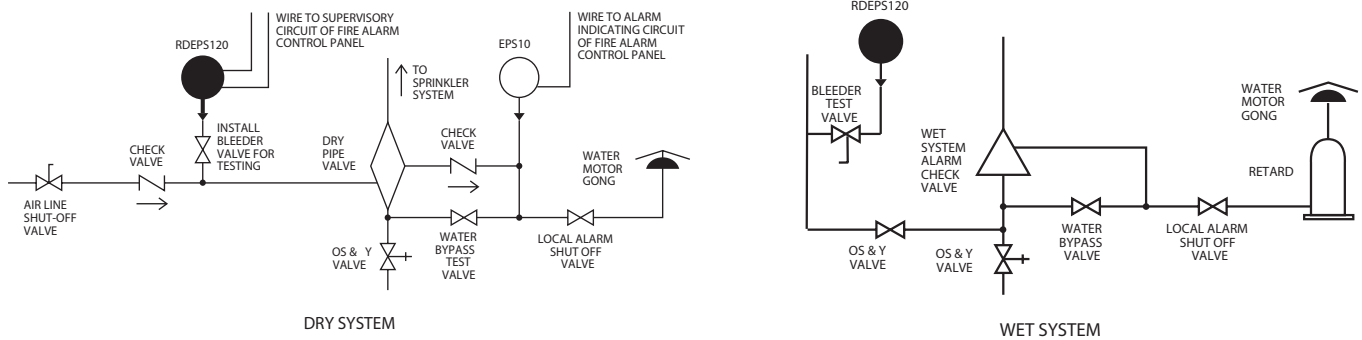

Single Switch Model RDEPS120-1

1. Install pressure switch as stated in "INSTALLATION" portion of instruction manual. Attach pressure test source to system.
2. Back off locking screw (see Fig. 2) to allow main adjustment wheel to rotate freely.
3. Test the switch for the set point by introducing 115 PSI pressure from the pressure test source for the RDEPS120-1. Decrease pressure slowly until the switch trips. Rotate main adjustment wheel, Figure 5, (counterclockwise to increase pressure) and retest by first introducing a higher pressure than desired and slowly reducing pressure until the switch trips. Repeat process until switch trip point is at desired pressure setting. Each number represents an approximate trip point change of 6.6 PSI for the RDEPS120-1. For each 1/2 rotation of the adjustment wheel, the trip point setting changes by approximately 40 PSI for the RDEPS120-1.
4. Retest the set point several times to ensure accuracy of setting.
5. Re-seat locking screw

Figure 2. Switch Location

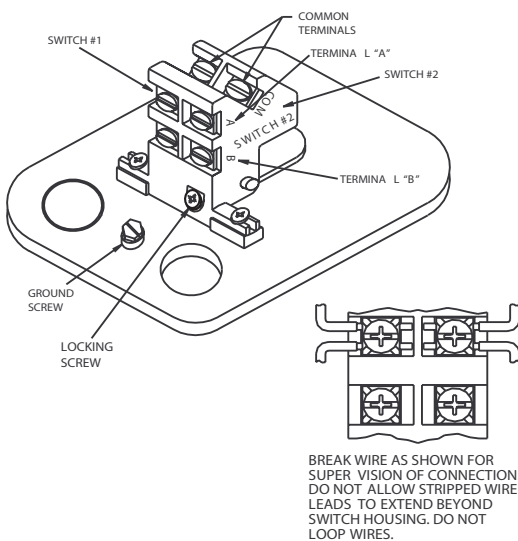

Factory Setting

Model	Fall Switch 2 (Low Switch)	Nominal	Rise Switch 1 (Hi Switch)
RDEPS120-1	101.5 - 112.5 psi	115 psi	-
RDEPS120-2	101.5 - 112.5 psi	115 psi	117.5 - 128.5 psi

Dual Switch Model RDEPS120-2

1. Install pressure switch as stated in "INSTALLATION" portion of instruction manual. Attach pressure test source to system.
2. Back out the locking screw (see Fig. 2) to allow main adjustment wheel to turn freely.
3. **Option 1:** Adjust nominal pressure setting without affecting PSI window.
 - a) Adjust main adjustment wheel (see Fig. 4) to desired setting using pressure source (i.e., valve or air maintenance device).
 - b) Turn main adjustment wheel counterclockwise to increase (see arrow on mounting base) or clockwise to decrease pressure. Each number on main adjust wheel represents an approximate window shift of 6.6 psi for RDEPS120-2. For each 1/2 rotation of the adjustment wheel the window changes by approximately 40 psi for RDEPS120-2.
 - c) Retest the set point several times to ensure the accuracy of the setting.
- Option 2:** Adjust pressure window size and nominal setting of pressure window.
 - a) Adjust main adjustment wheel (see Fig. 4) until high switch (SW1) trips at desired pressure using pressure test source (valve or air maintenance device).
 - b) Refer to step B from Option 1.
 - c) Decrease pressure until the low switch trips (SW2).
 - d) Adjust 1/4" low pressure hex head nut (see Fig. 5) to either increase (counterclockwise) or decrease (clockwise) the window size (the low switch will be affected).
 - e) The approximate sensitivity of the hex screw adjustment: 1/2 turn = 5 psi. A maximum of 30 psi is attainable.
4. Retest the set points several times to ensure the accuracy of the settings, and adjust as necessary.
5. Re-seat locking screw.

Supervisory Pressure Switches Fig. RDEPS120-1 and RDEPS120-2

Figure 3. Electrical Connections

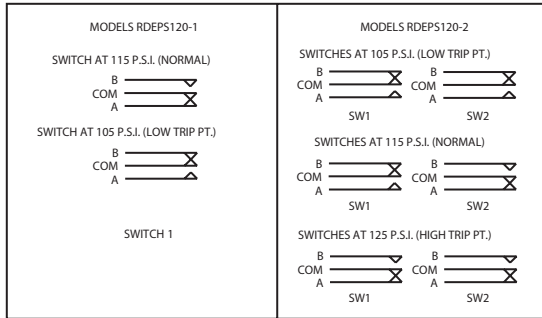

NOTE: The sensor assembly is not field replaceable. Do not attempt to disassemble these parts. If you have any questions, consult Rapidrop. Rapidrop recommends careful consideration of the following factors when specifying and installing Alarm and Supervisory Pressure Switches. Always refer to the Installation and Maintenance Instruction for specific recommendations on individual devices before installing the unit.

- Electrical ratings stated in literature and on nameplates should not be exceeded.
- Overload on switch can cause failure on the first cycle. Always wire devices according to national and local electrical codes.
- Install units away from shock and vibration. Proper electrical fittings should be used to prevent moisture from entering the enclosure via the conduit.
- Test all devices for proper operation after initial installation. Perform preventive maintenance and periodic testing as required by the applicable NFPA standards but not less than bimonthly.
- Install a back-up control for all critical applications where control failure could endanger life or property. A backup control to serve as a high or low limit control is especially recommended for applications where a runaway condition could result.
- Do not mount unit where ambient temperatures will exceed published limits.
- Avoid impact or mechanical loading.

Figure 4. Adjustment (Dual-Switch Model)

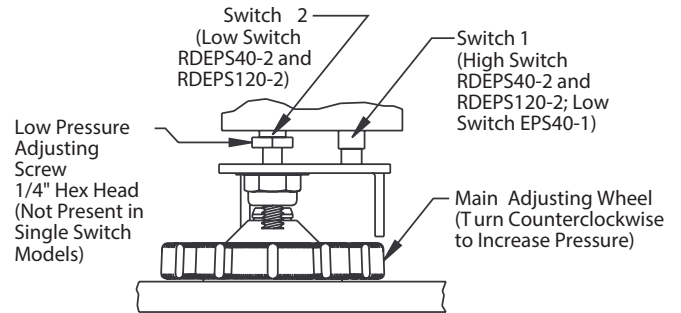

NOTE: Each 1/2 turn of Low Pressure adjusting screw adjusts pressure approximately 5 psi. Turn counter clockwise to increase pressure. Turn clockwise to decrease pressure. Each 1/2 turn of High Pressure adjusting wheel adjusts pressure 11 psi on the RDEPS40-2 and 40 psi on the RDEPS120-2.