



# Residential and Domestic Alarm and Test Valve Assembly

## General Description

Rapidrop offer an innovative, compact and affordable residential alarm valve test assembly for use that covers all the requirements of BS9251 for use in all domestic and residential properties. Valve can be installed in either the vertical or horizontal orientation.

## Features

- Ball valve with lockable handle
- Fewer joints minimises risk of leaks
- Factory fitted pressure gauge
- Available with WFDTN or Compact flow switch
- Full bore test valve.
- Glycerine filled 12 bar pressure gauge to EN837-1
- Compact and space saving design
- Quick and easy installation
- Fully compatible with CPVC fire sprinkler systems

## Working Pressure

Max. working pressure 12 bar (175 psi)

## Connections

### Inlet and Outlet:

BSP Tapered threads in accordance with ISO7-1

### Flow Switch:

1" NPT Tapered threads in accordance with ANSI/ASME B1.20.1

## Standards

Conforms to BS9251:2014

## Flow Switches

### System Sensor WFDTN switch

- Adjustable signal delay
- Two sets of SPDT contacts
- FM Approved, UL Listed
- Suitable for indoor and outdoor use
- Adjustable sensitivity

### Compact Switch

- One SPDT contact
- Adjustable sensitivity
- Compact, space saving design

## Optional extras

- WFDTN or Compact Water flow detector
- WRAS Approved Double Check Valve
- Available assembled with CPVC mating sockets
- Bespoke solutions available

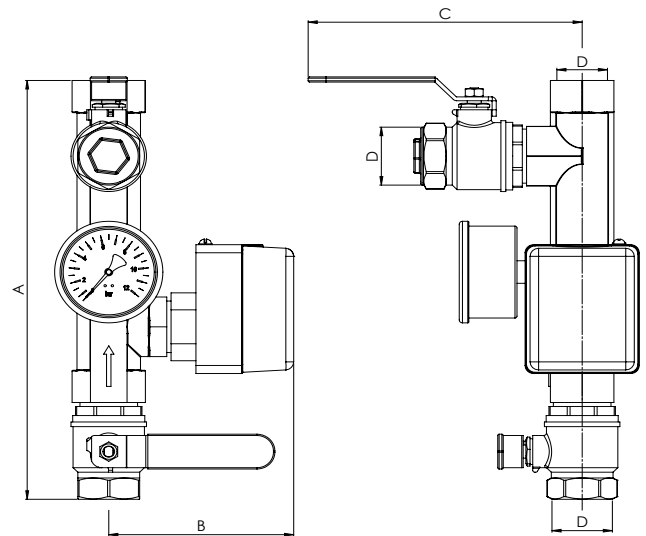
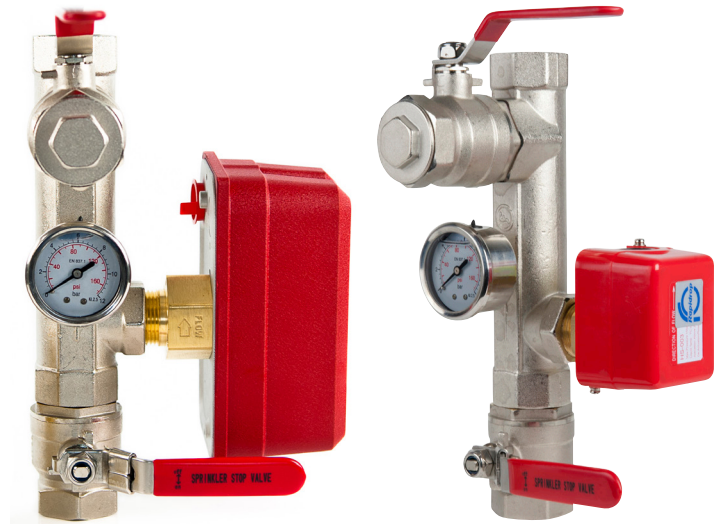

## Dimensions

Riser Size	A	B	C	D
DN25 1"	260	114 (Compact Switch)	164	Rc1 1" BSP Thread
		134 (Standard Switch)		
DN32 1 1/4"	278	120 (Compact Switch)	187	Rc1 1 1/4" BSP Thread
		140 (Standard Switch)		
DN40 1 1/2"	305	123 (Compact Switch)	197	Rc1 1 1/2" BSP Thread
		143 (Standard Switch)		
DN50 2"	Special order			



# Residential and Domestic Alarm and Test Valve Assembly

### Installation Guide

The following notes are intended as a basic guide to assist installation and form part of the manufacturers warranty.

- Ensure correct tools are used for installation, never use grip type tools on the manifold.
- Installation should always be carried out by a suitably qualified person.
- Always use a combination of pipe joint compound and PTFE Teflon tape to make connections to the manifold.
- Apply pipe joint compound to the female thread.
- Apply PTFE tape to the male thread, then apply a thin coat of pipe joint compound over the PTFE tape.
- Ensure the paddle of the flow switch does not interfere with the internal sides of the manifold
- Do not over tighten connecting fittings/components.
- The manifold is designed to fit most flow switches. Always check appropriate manufacturers data sheet for suitability.
- To ensure the manifold is securely positioned, bracket within 150mm from top and bottom connections.

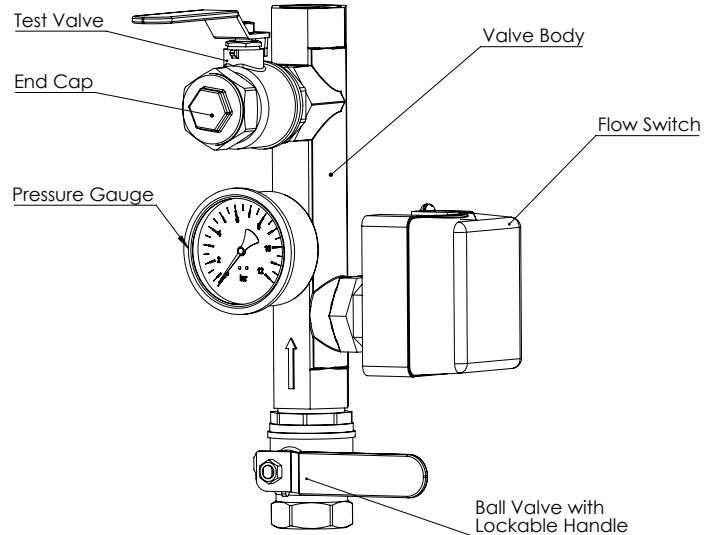

### Material Specification

Number	Part	Material
1	Valve Body	Brass HPb59-1 Nickel Plated
2	Male/female threaded ball valve (with lockable handle)	Brass HPb59-1 Nickel Plated
3	Male/female threaded ball valve	Brass HPb59-1 Nickel Plated
4	End Cap	Brass HPb59-1 Nickel Plated
5	Sealing gasket	PTFE
6	O-Ring	NBR



## Residential and Domestic Alarm and Test Valve Assembly

### System Testing Procedure

1. Ensure that the water to be discharged from the test valve will not cause damage or injury, and that the property owner / occupier is in agreement with the method of discharge.
2. It is recommended that the building occupants and any other interested parties, such as alarm monitoring stations, are notified prior to the alarm test.
3. Connect the test rig, including ideally a calibrated flow meter, onto the test line.
4. Fully open the test valve.
5. Verify the residual (flowing) pressure indicated by the pressure gauge is no less than that originally recorded at the commissioning of the system.
6. Record the litres per minute.
7. Compare the findings with the design criteria of the installed system.
8. If the test fails to achieve the minimum required, trouble shoot as per guidance notes.
9. Ensure a visible or audible alarm (as relevant) is activated.
10. If the test fails to activate the alarm, trouble shoot as per guidance notes.
11. Close the test valve.
12. Remove the test rig.
13. Continue with system specific checks as required.

### Item Number

Item Number	Description
RDRESIVALVESET25	DN25 (1") Residential valve set, single port
RDRESIVALVESET32	DN32 (1 1/4") Residential valve set, single port
RDRESIVALVESET40	DN40 (1 1/2") Residential valve set, single port
RDWFDT	Residential Flow Switch
DRSO21G	Compact Flow Switch
RDDCV25WRAS	DN25 (1") WRAS approved double check valve
RDDCV32WRAS	DN32 (1 1/4") WRAS approved double check valve
RDDCV40WRAS	DN40 (1 1/2") WRAS approved double check valve

### Important Installation Information

- Rapidrop *Residential Riser* must only be installed by a competent person in accordance with requirements of the local authority having jurisdiction. Deviations from these standards will invalidate warranty.
- It is the responsibility of the installing contractor to include a copy of this document in the sprinkler system installation, operating and maintenance manual.
- Alterations to Rapidrop products will void any warranty.
- *Residential Riser* should be inspected and maintained during routine sprinkler system inspections by a competent person in accordance with national codes/requirements.
- Failure to follow these instructions could cause improper operation, resulting in personal injury and/or property damage.
- For further details and technical support please contact your Rapidrop sales representative.