



## 4" Dry Pipe Valve (Grooved / Grooved) Model E



### Product Description

The Rapidrop 4" Dry Pipe Valve model E is essentially a differential check valve. The bronze clapper carries two rubber gaskets. The larger (air ) gasket is rubber and seats against pure tin. The smaller (water ) gasket is a specially designed rubber disc, which also seats on pure tin. These seats are proportioned so that one pound ( .454 kg) of air pressure will hold back approximately six pounds (2.722 kg) of water pressure.

When the air pressure on the sur face of the priming water is relieved by the opening of a sprinkler , the upward pressure of the water underneath the water gasket causes the clapper to lift, the intermediate chamber instantly fills , sounds the alarm, and the water pressure, acting on the entire sur face of the clapper , pushed it over to the wide open position and thus leaves a passage for the water to the sprinkler system.



### Resetting

Close main controlling valve or post indicator to shut off water supply to sprinkler system.

2. Open Valve 1 to drain sprinkler system.
3. Gong and electric valve may be shut off by closing valve 2.
4. Vent sprinkler system by opening 3/4" (19.05 mm) inspector 's test valve which is normally located at the top of the system.
5. After system is thoroughly drained, remove cover plate 3 for resetting dry valve.
6. Raise clapper off seat and scoop out any scale or solid particles found in intermediate chamber , in the bottom of the valve, between the air and water seats. Using a clean piece of cloth wipe the sur face of the rubber seats on the swinging clapper, also the tin seats in the valve. Never apply grease, tallow, or any other substance to water or air seat.
7. Let bronze clapper down on its seat making sure that the rubber air ring presses evenly all around the air seat.
8. Put on cover plate 3 making sure that gasket is in good condition. Replace nuts and tighten evenly, a little at a time, all around.
9. Drip valves are found at low points ( if any) on sprinkler piping. They would not be drained by previous operation - open these valves for draining after removing plugs and close when water stops running.
10. Close 3/4"(19.05 mm) inspector's test valve, previously opened to vent system.
11. Replace sprinklers fused by fire.
12. Prime by opening valve 4 and slowly pour water into

priming cup 5 until priming level is even with cup. Remove plug 7 in valve 6 which is normally open; after water stops running replace plug 7 and close valve 4 tightly. Water must not be allowed to stand above the priming water level.

13. Open valve 8 and pump air pressure into system. When ten (10) pounds (4.536 Kg) pressure has been built up, open drip valve again to force water from low points of system. Close drip valves tightly and plug.

14. Pump the correct air pressure into the sprinkler system, then close valve 8 tightly. Make sure there is no leakage of priming water by the rubber air seat into drip cut 10 by observing automatic drain valve 9.

Note: Never allow air pressure to drop below minimum limit, to safeguard against accidental tripping of dry valve.

Air pressure required for sprinkler system should be calculated at approximately one (1) P.S.I. of air for every six (6) P.S.I. of water pressure. The air pressure should be maintained at approximately twenty (20) P.S.I. above calculated air pressure per N.F.P.A.-13.

15. Partly close valve 1- then open main controlling valve slowly, until water is heard flowing through drain valve 1 - then close tightly, and open controlling valve fully and seal.

Note: This flushes the seat in valve 1 and prevent the clapper from raising, by opening main controlling valve too suddenly.

16. To check water seat inside the dry pipe valve, look at the automatic drain valve 9, and make sure that no water is leaking into drip cup 10.

17. Open automatic drain valve 9 to be sure no water remains in pipe to alarm devices, then close.

18. Valve 2 should now be opened.

Manufactured by Venus who hold the LPCB approval.

DS: 5.14  
Issue A  
28/08/2015  
© 2015 Rapidrop

Rapidrop Global Ltd  
T: +44 (0) 1733 847 510 F: +44 (0) 1733 553 958  
e: rapidrop@rapidrop.com  
w: www.rapidrop.com



### 4" Dry Pipe Valve (Grooved / Grooved) Model E



#### Inspection & Maintenance

A minimum of two people should be familiar with the sprinkler system but at least one should be held responsible for its proper maintenance.

1. Test main riser for water to make sure dry pipe valve is not water columned. Water should be up to but not above the level of valve 6.
2. Close main control valve. Open main drain valve 1.
3. Close valve 6 and remove plug 7. Open 6 to drain water which is above the level of this valve. Replace plug 7 and open valve 6. Check air pressure according to N.F.P.A. -13. Close drain valve 1 and the open main control valve.
4. Air pressure must be maintained and checked weekly, under normal conditions. During freezing weather it should be checked daily. Check valve 8 in the fall before freezing weather sets in to assure a tight seat.
5. Alarm devices may be tested occasionally without tripping the dry pipe valve by opening valve 11 if weather permits.
6. Drip valves or drum drips should be drained before freezing weather sets in and occasionally during winter .

Note: We also recommend at least an annual inspection by qualified inspectors of the complete fire protection system. Many times defects maybe detected during inspection and repairs made before they develop into major troubles which might mean the protection would be off in your plant for several days.

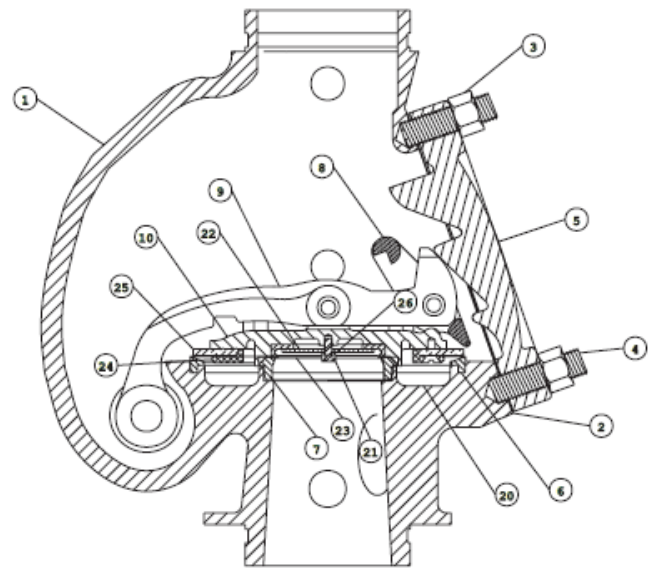

#### Parts List

Item	Part No.	DWG No.	Description
1		DPVE 4004	Body
2	D-2	DPV 4031	Cover Gasket
3	ON-12A	DPV 4033	Heavy Hex. Nut
4	D-268	DPV 4032	Cover Plate Stud 3/4"
5	D-47	DPV 4007	Cover
6		DPV 4012	Air Seat
7		DPV 4040	Water Seat
8	D-34	DPV 4024	Latch
9	D-29	DPV 4009	Clapper Arm Assembly
10	D-2274	DPV 4019	Clapper Assembly
11	D-33	DPV 4021	Arm Hinge Pin Plug
12		DPV 4022	Asbestos Gasket
13		DPV 4025	Arm Pin Bushing
14	D-30	DPV 4020	Arm Hinge Pin
15	OPC-3-10A	DPV 4030	Cotter Pin Brass
16		DPV 4026	Clapper Pin Bushing
17		DPV 4027	Latch Pin Bushing
18	D-31	DPV 4029	Latch Pin
19	D-32	DPV 4028	Clapper Hinge Pin
20	OMS-16-10A	DPV 4018	Machine Screw
21		DPV 4016	Hex Cap Screw
22	D-2272	DPV 4013	Water Seat Disc
23	D-2273	DPV 4015	Water Seat Gasket
24	D-38	DPV 4035	Air Seat Retainer
25	D-40	DPV 4014	Air Seat Gasket
24		DPV 4017	Lock Washer

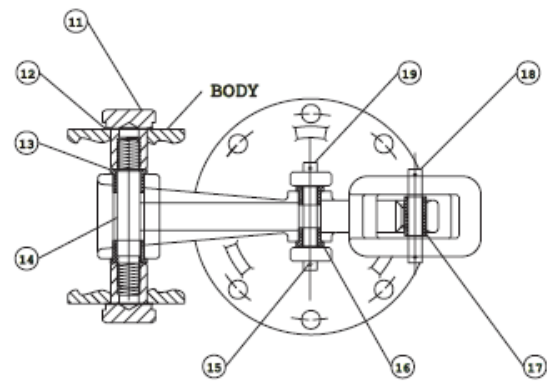

4" Dry Pipe Valve Model E	
Face to Face	15 1/4"
Weight	112 lbs.

Manufactured by Venus who hold the LPCB approval.

DS: 5.14  
Issue A  
28/08/2015  
© 2015 Rapidrop

Rapidrop Global Ltd  
T: +44 (0) 1733 847 510 F: +44 (0) 1733 553 958  
e: rapidrop@rapidrop.com  
w: www.rapidrop.com



### 4" Dry Pipe Valve (Grooved / Grooved) Model E



#### Key to Trimming

1. Drain Valve - for draining of sprinkler system
- 2" (5.08 cm) Angle Valve.
2. Alarm Shut-off - 3/4" (19.05 mm) Ball Valve.
3. Cover Plate - for resetting Valve.
4. Priming Water Valve - 1/2"(12.7 mm) Angle Valve.
5. Priming Cup.
6. Gauge Valve.
7. Priming Level Test Plug.
8. Air Supply Valve - 3/4" (19.05 mm) Angle Valve.
9. Automatic Drain Valve (D.V.D.).
10. Air Pressure gauge.
11. Alarm Test Valve - 3/4" (19.05 mm) Angle Valve.
12. 3/4" (19.05 mm) Check Valve.
13. Water Pressure Gauge.

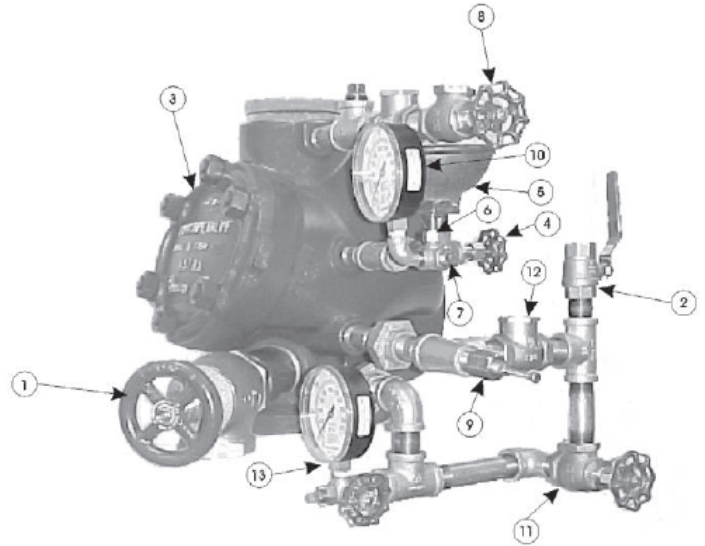

Face to face: 15 1/4"

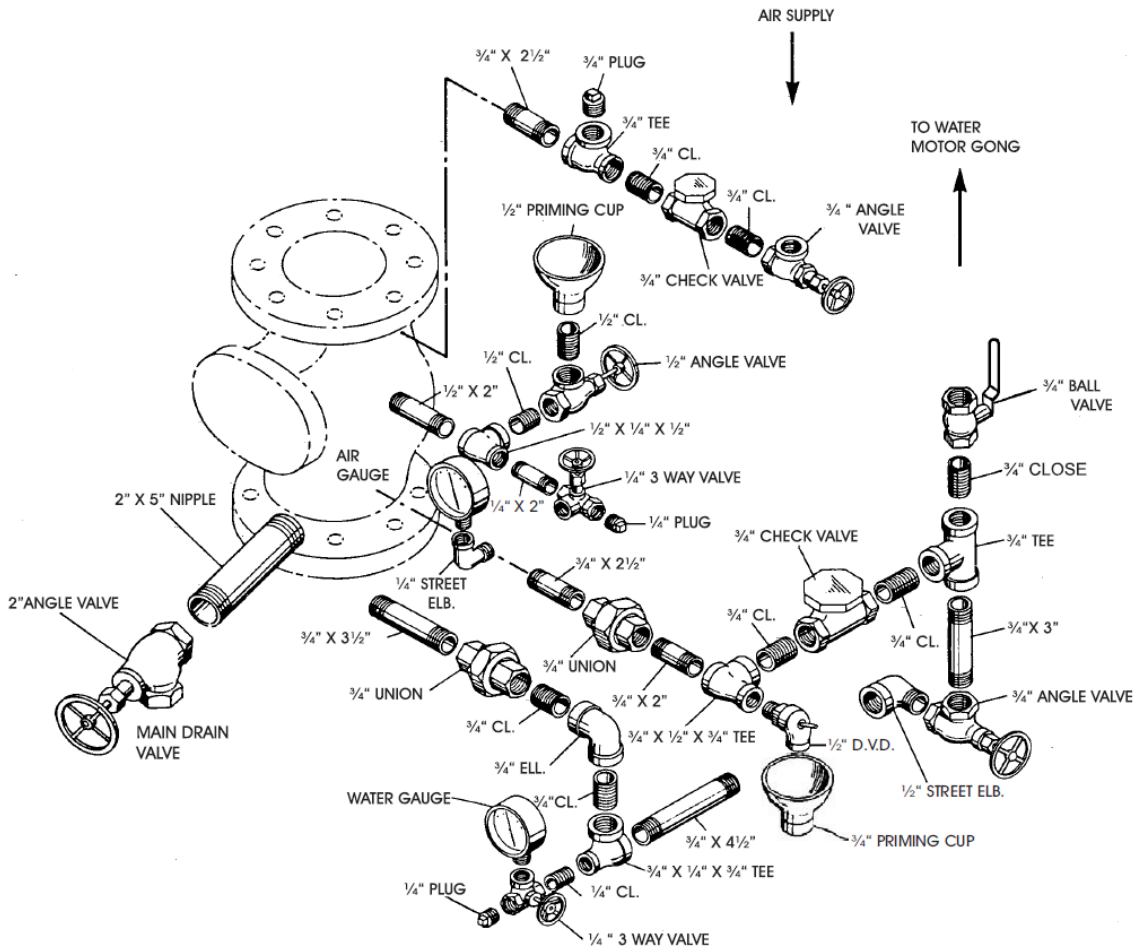

Manufactured by Venus who hold the LPCB approval.