

Dry Pilot Line Single Interlock Preaction System 8' (200 mm) Size

Instructions for Installation, Operation, Care and Maintenance

- 8 psi to 26psi (0,6 bar to 1,8 bar) Pneumatic Pressure
- Externally Resettable Clapper
- One Main Drain

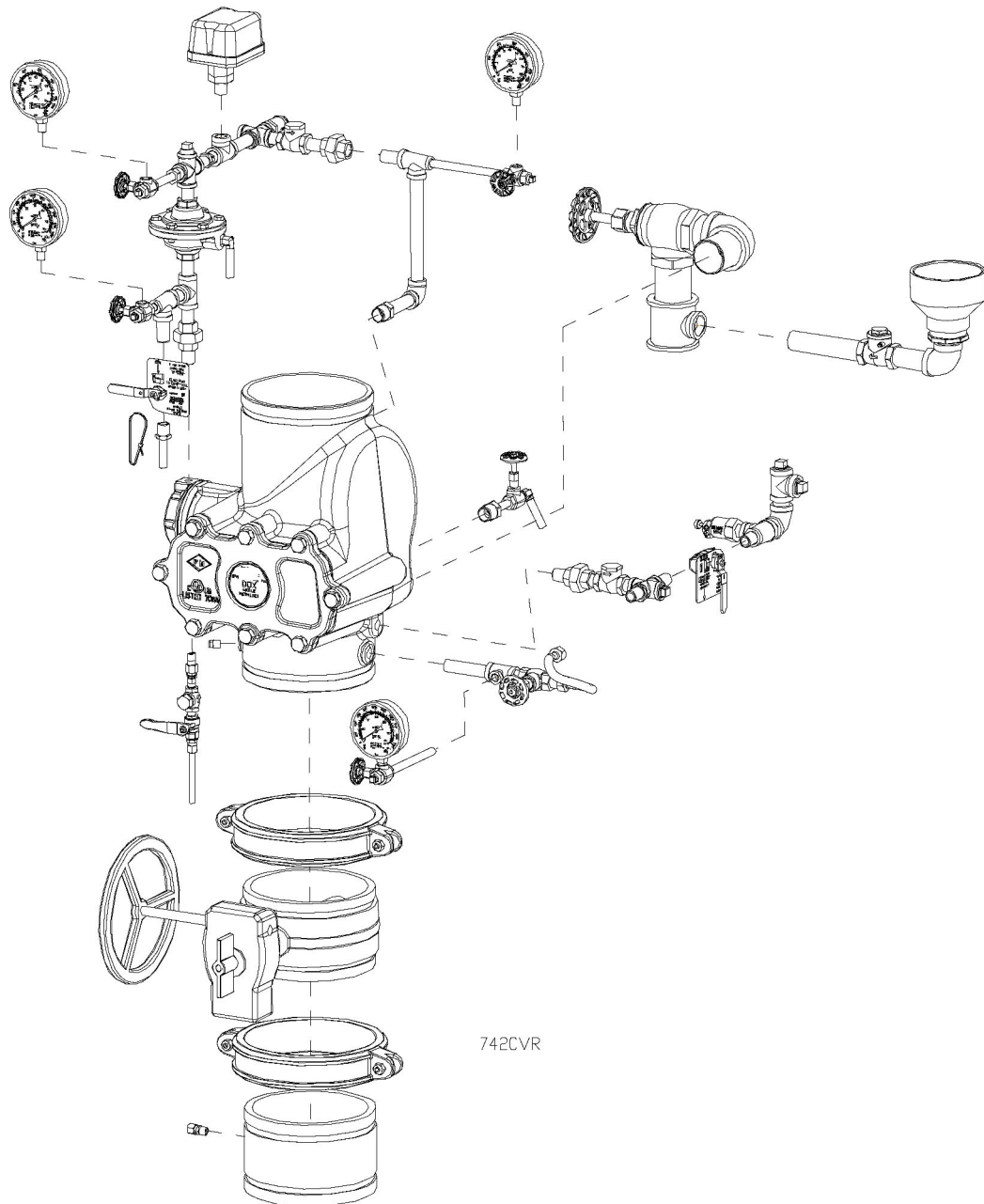



Dry Pilot Line Single Interlock Preaction System 8' (200 mm) Size

General Description

Single Interlock Dry Pilot Line Preaction Systems are designed for water-sensitive areas that require protection from inadvertent water flow into the sprinkler system piping. Dry pilot operation is used in areas that may be subjected to freezing conditions. They can also be utilized to obtain installed sprinkler heights and pipe lengths greater than the allowed for wet pilot systems. A dry pilot line installation consists of an air-pressurized line of closed sprinklers or pilot line detectors (Rapidrop's Model F1-FTR), which are located in the area to be protected. NFPA 72 or the Authority Having Jurisdiction (AHJ) should be consulted for spacing and elevation requirements for the installation of dry pilot sprinklers/detectors.

In the system's trim, the dry pilot line is connected to a Model LP Dry Pilot Line Actuator. This actuator functions very much like a miniature dry pipe valve. It requires only 8 to 26 psi (0,6 to 1,8 bar) of air pressure (depending on the water supply pressure) to maintain the Model DDX Deluge Valve in a closed position. In areas where moisture-laden air could cause a freezing condition, or other problems in the dry pilot line, the use of a dry, compressed gas such as nitrogen is suggested. Approved gas handling regulators (see Rapidrop Bulletin 251) and connections are recommended. When one of the dry pilot line sprinklers/detectors actuates, the air pressure in the line is reduced, thus opening the Model LP Dry Pilot Line Actuator, which in turn releases the DDX Deluge Valve and fills the fire sprinkler piping with water. However, water does not flow from the fire sprinkler system until one of its sprinklers fuses from the heat of the fire.

The fire sprinkler system piping maybe required to be supervised (see NFPA 13) with air pressure. Loss of this supervisory air due to a damaged sprinkler or the sprinkler piping will not cause the Model DDX Deluge Valve to open. This is accomplished by the W' check valve which is located in the valve's trim. The check valve prevents air pressure (from the dry pilot line) from escaping out of the Model LP Dry Pilot Line Actuator. A low air pressure switch (System Sensor EPS40-2 or EPSA40-2) is also provided in the trim. The contacts of this switch will close on the loss of air in the sprinkler piping, thereby providing a low air alarm to aid in insuring the integrity of the sprinkler system piping. The pressure switch's low air alarm should be wired to a supervisory alarm bell or the building's alarm system (Note: the wiring for a closing of the contacts on the loss of air are the "Common" and "B" contacts). Damage that causes a loss of air pressure to a dry pilot line sprinkler/detector or the dry pilot line piping will cause the Model DDX Deluge Valve to open, flowing water into the fire sprinkler system piping. The supervisory air supply for both the dry pilot line and the fire sprinkler piping can effectively be supervised by means of pressure-switch-operated, tankmounted air compressor and a Rapidrop Model A-2 Pressure Maintenance Device (see Rapidrop Bulletins 250 & 251). The compressor's tank provides a reserve supply of air, whereas the Model A-2 Pressure Maintenance Device consistently regulates the air pressure of both the dry pilot line and the fire sprinkler piping.

The dry pilot line sprinklers/detectors must be more sensitive to the heat from a fire than the sprinklers in the fire sprinkler system. The Model F1-FTR (Fixed Temperature Release) is specifically designed for use in dry pilot line operated sprinkler systems. Dry pilot line sprinklers are detection devices and do not provide any water to aid in the firefighting capability of the fire sprinkler system.

To fully operate a dry pilot line preaction system, the heat from a fire must fuse a dry pilot line sprinkler/detector thereby releasing the air pressure from the Model LP Dry Pilot Line Actuator. The water pressure is then able to overcome the pressure differential of the actuator, allowing water to flow from the Model DDX Deluge Valve's push rod chamber. As this water pressure is lost in the push rod chamber, valve's clapper flowing water into the fire sprinkler system piping. Water flowing into the system will flow through the intermediate chamber of the deluge valve to a mechanical sprinkler alarm (optional) and/or will simultaneously produce water pressure that causes the transfer of contacts in the (optional) alarm pressure switch mounted in the trim. If provided, the alarm pressure switch can electrically initiate the shut-down or start up of equipment, such as computer, HVAC, or other secondary alarm devices (Note: the wiring contacts for the alarm pressure switch are the "Common" and "A" contacts). The flow of water into the sprinkler system piping converts the dry system into a wet system. In the event that the fire subsequently produces enough heat to operate a fire sprinkler head, water will flow from that sprinkler, controlling or suppressing the fire. At the heart of Rapidrop's Dry Pilot Line Single Interlock Preaction System is the Model DDX Deluge Valve. This deluge valve is a hydraulically operated, straight-through design, differential latching clapper-type (see Fig. 1). System maintenance is simplified since the deluge valve can be reset externally without removing its cover plate. This feature provides a significant system-restoration time advantage. The Model DDX Deluge Valve has an intermediate chamber and thereby does not require an in-line air check valve. Also, for ease of installation, the deluge valve only requires a single drain connection.

The trim set for the system (see Fig. 2) provides all of the necessary equipment for connections to the Model DDX Deluge Valve's push rod chamber inlet and outlet ports, the 2" (50mm) main drain, alarm devices, air supply, and required pressure gauges. This trim set is available in individual (loose) parts, in time-saving, segmented assembled kit forms or fully assembled to the Model DDX Deluge Valve (with or without a control valve).

Listings & Approvals

Rapidrop's 8" (200mm) Dry Pilot Line Single Interlock Preaction Systems are Underwriters Laboratories, Inc. Listed and UL certified for Canada (cULus) in the Special System Water Control Valve-Deluge Type (VLFT) category. Rapidrop Single Interlock Preaction Systems are UL Listed Only when used with the trim components shown in Fig. 2.

Dry Pilot Line
Single Interlock Preaction System
8' (200 mm) Size

REAR VIEW OF MODEL
DDX VALVE

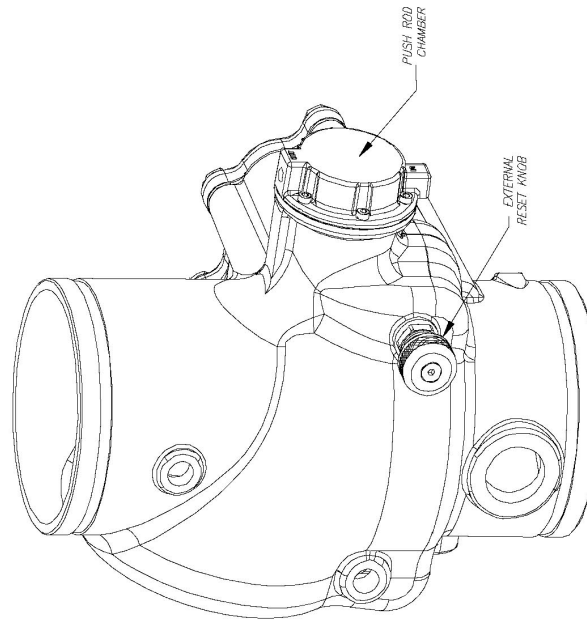

PUSH INWARD AND ROTATE KNOB CLOCKWISE TO RESET CLAPPER.
DO SO ONLY WHEN PUSH ROD CHAMBER IS VENTED.

DDX VALVE CLAPPER IN "OPEN", "CLOSED"
AND "LATCHED" POSITIONS

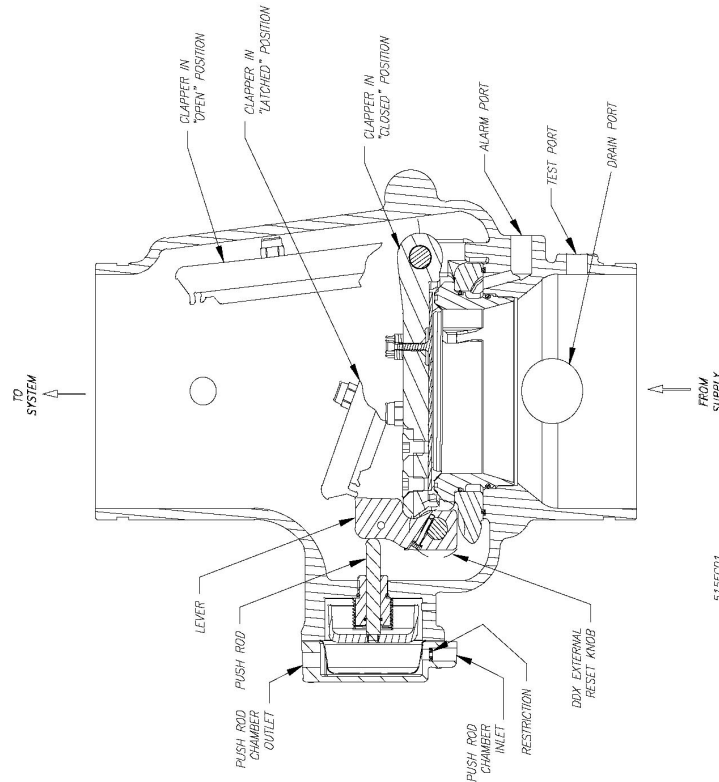

Dry Pilot Line Single Interlock Preaction System 8' (200 mm) Size

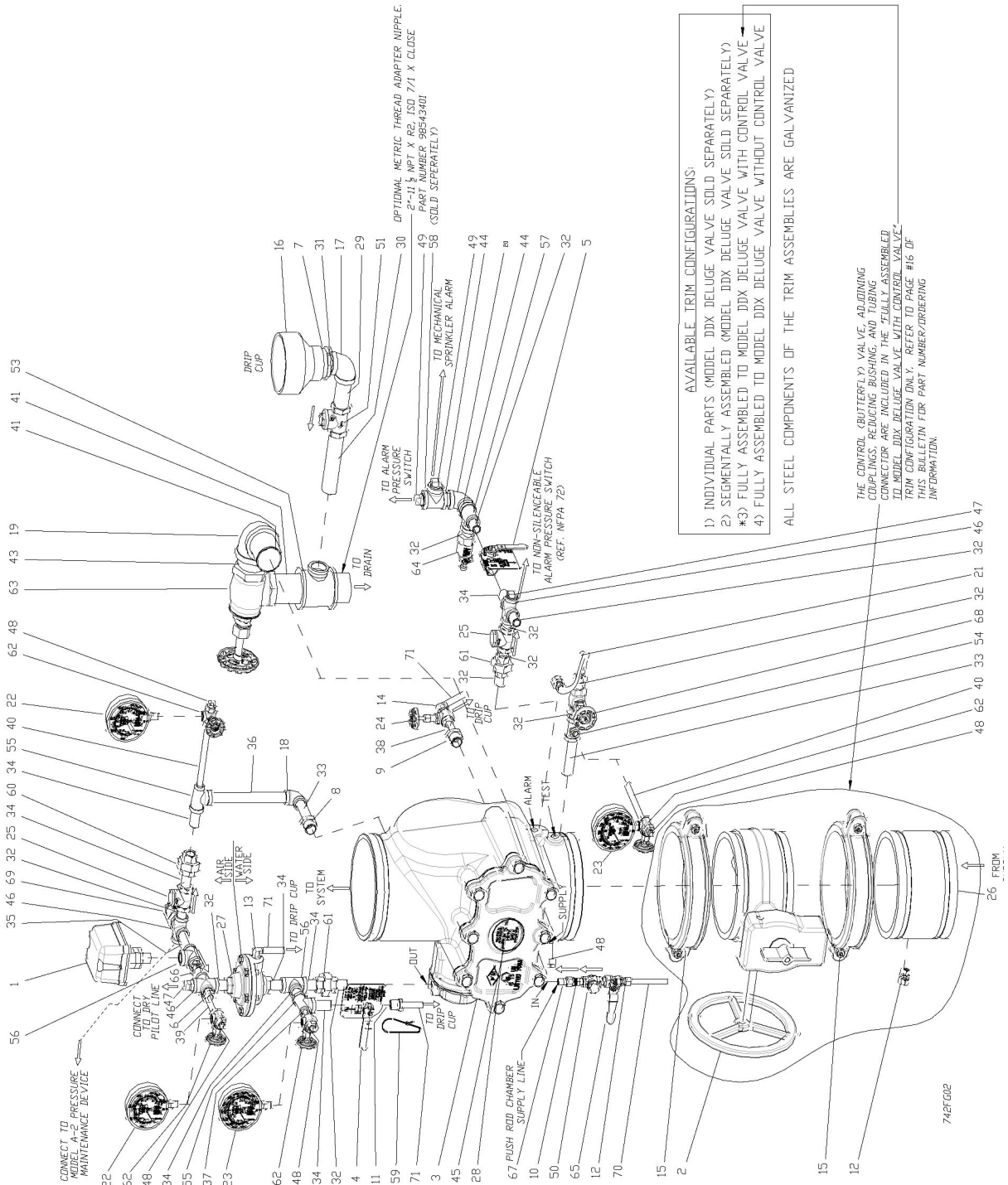

Rapidrop Global Ltd reserves the right to change the design, materials and specifications without notice to continue product development



Dry Pilot Line Single Interlock Preaction System 8' (200 mm) Size

Dry Pilot Single Interlock Trim Parts List (Refer to Fig. 2)

ITEM NO.	PART NO.	DESCRIPTION	QTY.
1	6999991340	Switch, Pressure (EPS10-2) UL/FM	1
	6999992361	Switch, Pressure (EPSA10-2) ULC	
2	6215053200	8" UL/FM Butterfly Valve	1
3	6103080001	Assembly, Duluge Dry Valve	1
4	78653000	Assembly, Manual Emergency Station	1
5	78653004	Assembly, Valve Caution Station, 1/2"	1
6	98048000	Bushing, Reducer, 1/2" x 1/4", Galv.	1
7	98048015	Bushing, Reducer, 2" Spigot x 1" NPTF, PVC	1
8	98048022	Bushing, Reducer, 3/4" x 1/2", Galv.	1
9	98048025	Bushing, Reducer, 3/4" x 1/4", Galv. 1	1
10	98840147	Check Valve, 1/4" NPT, Poppet Type Inline	1
11	92056810	Connector, 3/8" ID Tube x 1/2" NPT	1
12	92056702	Connector, 3/8" Tubing x 1/4" NPT	2
13	92056704	Connector, Elbow, 3/8" ID Tube x 1/2" NPT	1
14	92056705	Connector, Elbow, 3/8" Id Tube x 1/4" NPT	1
15	7G05323200	Coupling, Rigid, 8"	2
16	98050004	Drain Cup, PVC	1
17	98174403	Ell, 1", Mall Iron, Galv.	1
18	98174401	Ell, 1/2", Mall Iron, Galv.	1
19	98174405	Ell, 2", Mall Iron, Galv.	1
20	98174402	Ell, 3/4", Mall Iron, Galv.	1
21	96920912	Flex Line, 12"	1
22	98248000	Gauge, Air Pressure (0-80 PSI)	2
23	98248001	Gauge, Water Pressure (0-300 PSI)	2
24	98840172	Globe Valve, 1/4"	1
25	98840181	Horiz. Swing Check Valve, 1/2" NPT	2
26	91004288	Manifold, Supply, 8"	1
27	71030010	Model LP Pilot Line Actuator	1
28	94616917	Nameplate, Single Interlock	1
29	98543222	Nipple, Steel, Galv., 1" x 3-1/2"	1
30	98543266	Nipple, Steel, Galv., 1" x 6"	1
31	98543213	Nipple, Steel, Galv., 1" x Close	1
32	98543223	Nipple, Steel, Galv., 1/2" x 1-1/2"	11
33	98543216	Nipple, Steel, Galv., 1/2" x 3-1/2"	2
34	98543209	Nipple, Steel, Galv., 1/2" x 2"	7

ITEM NO.	PART NO.	DESCRIPTION	QTY.
35	98543230	Nipple, Steel, Galv., 1/2" x 3"	1
36	98543237	Nipple, Steel, Galv., 1/2" x 8"	1
37	98543226	Nipple, Steel, Galv., 1/4" x 1-1/2"	1
38	98543225	Nipple, Steel, Galv., 1/4" x 2-1/2"	1
39	98543220	Nipple, Steel, Galv., 1/4" x 3"	1
40	98543217	Nipple, Steel, Galv., 1/4" x 6"	2
41	98543262	Nipple, Steel, Galv., 2" x 3-1/2"	2
42	----	----	--
43	98543238	Nipple, Steel, Galv., 2" x Close	1
44	98543279	Nipple, Steel, Galv., 3/4" x Close	2
45	99080002	Pad-adhesive	1
46	98750003	Pipe Cross, 1/2", Galv.	3
47	98604406	Plug, Iron, Sq. Hd., 1/2"	2
48	98614403	Plug, Iron, Sq. Hd., 1/4"	5
49	98614401	Plug, Iron, Sq. Hd., 3/4"	2
50	98727607	Strainer, 1/4"	1
51	98840145	Swing Check Valve, 1" NPT	1
52	6999991340	Switch, Pressure (EPS40-2)	1
53	96606627	Tee, Glvn, 2" x 2" x 1"	1
54	96606607	Tee, Glvn., 1/2" x 1/2" x 1/4"	1
55	98761649	Tee, Glvn., 1/2" x 1/4" x 1/2"	2
56	98761651	Tee, Glvn., 1/2"	2
57	96606612	Tee, Glvn., 3/4" x 1/2" x 1/2"	1
58	96606601	Tee, Glvn., 3/4"	1
59	89141112	Tie, Retaining	9
60	98815204	Union, "O" Ring Seal, Galv., 1/2"	1
61	98815200	Union, 1/2", Iron, G.J., Galv.	2
62	98840160	Valve, 3-way, 1/4"	4
63	98840100	Valve, Angle, 2"	1
64	78653100	Valve, Ball Drip, 1/2"	1
65	98840117	Valve, Ball, 1/4" NPTF x 1/4" NPTM	1
66	96816904	Valve, Check, 1/2"	1
67	98840187	Valve, Check, 1/4" NPTF x 1/4" NPTM	1
68	98840171	Valve, Globe, 1/2"	1
69	98840190	Valve, Relief, 1/2", 40 PSI	1
70	96686722	Tubing, Copper, 3/8" O.D. x 2 Ft.	1
71	96686754	Tubing, PVC, 3/8" I.D. x 6 Ft.	1



Dry Pilot Line Single Interlock Preaction System 8' (200 mm) Size

System Operation

To fully operate (discharge water) a Dry Pilot Line Single Interlock Preaction System, two independent events must coexist before water flow will occur. A closed fire sprinkler head and a pilot line detector head must fuse open. Operation of just a fire sprinkler head will only cause a low air alarm to annunciate. The operation of just a pilot line detector head will cause the Model DDX Valve to trip open, but no water will be delivered to the fire until a closed fire sprinkler head is also fused open.

When set correctly for service, the Model DDX Deluge Valve is hydraulically established to withhold the supply water from the sprinkler system piping. The Rapidrop Model DDX Deluge Valve is shown in both closed and open positions in Fig. 1. In the closed position, the supply pressure acts on the underside of the clapper and also on the push rod through the push rod chamber's inlet restriction. The resultant force due to the supply pressure acting on the push rod is multiplied by the mechanical advantage of the lever and is more than sufficient to hold the clapper closed against normal supply pressure surges.

When a fire is detected, the Model LP Dry Pilot Line Actuator vents the push rod chamber to atmosphere through the chamber's outlet. Since the pressure cannot be replenished through the inlet restriction as rapidly as it is vented, the push rod chamber pressure falls instantaneously. When the push rod chamber pressure approaches approximately one-third of the supply pressure, the upward force of the supply pressure acting beneath the clapper overcomes the lever-applied force thereby opening the clapper. Once the clapper has opened, the lever acts as a latch, preventing the clapper from returning to the closed position. Water from the supply flows through the Deluge Valve into the system piping. Water also flows through the Deluge Valve alarm outlet to the alarm devices.

After system shutdown, resetting the Model DDX Deluge Valve is quite simple. Doing so only requires pushing in and turning the reset knob at the rear of the valve (see Fig 1). The external reset feature of the Model DDX Deluge Valve provides a means for simple, economical system testing, which is one essential facet of a good maintenance program. The external reset feature does not, however, eliminate another important facet of good maintenance, namely, periodic cleaning and inspection of the internal valve parts. In the event that water builds up inside the valve due to condensate from the air supply system or water left inside from valve system testing, a drain is available for venting. After closing the main supply valve, a small valve over the drain cup can be opened slightly until the water inside the valve body and the main pipe column has drained. See the section titled "Draining Excess/Condensate Water From System" in this bulletin for

the detailed procedure. The Model B Manual Emergency Station (see Fig. 3) is also included in the Rapidrop Dry Pilot Line Single Interlock Preaction System trim set. It consists of an aluminum nameplate mechanically attached to a ball valve. The valve handle in its OFF position is guarded against accidental turning to the ON position (and system discharge) by a nylon cable tie provided with each trim kit. The cable tie is inserted, as shown in Fig. 3, after the system has been restored for operation. The nylon cable tie is designed to allow, in case of an emergency, forceful turning of the valve handle to the ON position. As an alternative to the Model B Hydraulic Manual Emergency Station, the Model A Hydraulic Manual Emergency Pull Box (see Rapidrop Bulletin 506) is also available and can be provided as an option. Whenever ambient temperature conditions are high, the water temperature in the Model DDX Deluge Valve's push rod chamber could possibly increase, thereby increasing the pressure in the chamber to values exceeding the rated pressure of the system. In an indoor installation where standard room temperatures are exceeded, a pressure relief kit may be needed. Pressure relief kit, PIN 6503050001, can be installed into the pushrod chamber's releasing line to limit the pressure to 175 psi (12.1 bar).

Pressurizing Line Connection

The water supply for the push-rod chamber must be provided by connection of its inlet pressurizing line to the water supply piping. Pressurizing lines for multiple Model DDX Deluge Valve push-rod chambers must never be manifolded together, having only a single tap on the water supply piping. Each Model DDX Deluge Valve must have its own push-rod chamber pressurizing line connection. This connection must be made on the supply side of the main water supply control valve. This can be accomplished by:

- Using a tapped connection directly below or next to the main water supply control valve using a welded outlet or the appropriate mechanical fittings. A grooved-end outlet coupling is one way to achieve this; or
- Using a water supply control valve that has an available threaded (NPT) supply-side tap design to allow for a direct water supply connection to the Model DDX Deluge Valve's push-rod chamber.

Caution: Rapidrop's DDX valve is designed with an inlet restriction built into the push rod chamber. It is important not to introduce additional restrictions into the direct water supply connection or the discharge from the pushrod chamber by installing additional valves or improperly installing the copper lines used in the trim of the valve.

MODEL B HYDRAULIC MANUAL EMERGENCY STATION

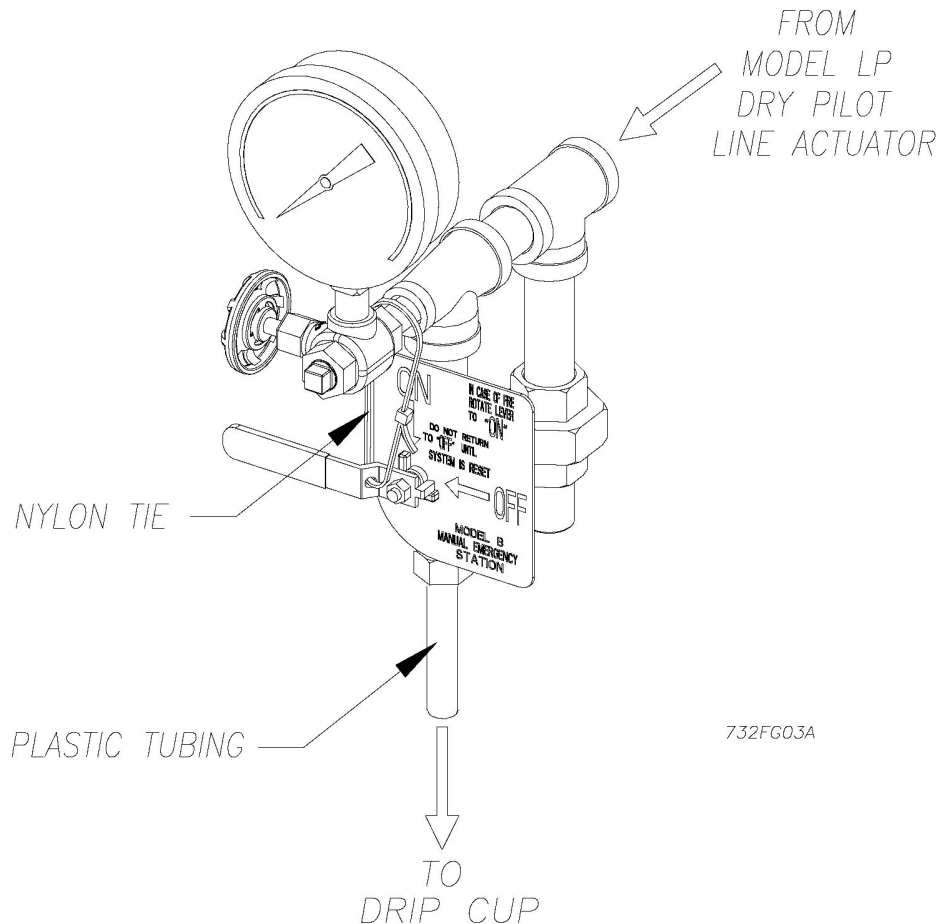

Fig. 3

Hydrostatic Testing of DDX Valves and DDX Systems

As required by NFPA 13, fire sprinkler systems with working pressures up to and including 150 psi are to be hydrostatically tested at a water pressure of 200 psi and maintain that pressure without loss for two hours. Fire sprinkler systems with working pressures above 150 psi are required to be hydrostatically tested at 50 psi above the system working pressure and maintain that pressure without loss for two hours. In addition to the hydrostatic tests described above, dry pipe and double interlock preaction systems require an additional low pressure air test.

In some cases, hydrostatic testing (in accordance with NFPA 13 requirements noted above) will result in pressures that exceed the working pressure of the valve and trim kit for the two-hour

period. The valve and applicable trim kit have been tested, approved and listed under these conditions and as such, hydrostatic testing in accordance with NFPA 13 is acceptable. In addition, the clapper can remain in the closed position and the trim kit need not be isolated, as each has been designed to withstand hydrostatic testing as required by NFPA 13.

Hydrostatically testing the valve and trim to pressures higher than their rating is limited to the hydrostatic test as referenced by NFPA 13. It does not address the occurrence(s) of a "water hammer" effect, which can indeed damage the valve. A "water hammer" in the water supply piping of the valve can create pressures in excess of the rated pressure and should be avoided by all necessary means. This condition may be created from improper fire pump settings, underground construction work, or improper venting of trapped air in the water supply piping System Design Consideration.



Dry Pilot Line Single Interlock Preaction System 8' (200 mm) Size

System Design Considerations

The automatic sprinklers, air compressor, releasing devices, electric releasing control equipment, fire detection devices, manual pull stations, and signaling devices which are utilized with the Dry Pilot Line Single Interlock Preaction System must be UL or ULC Listed, as applicable. The Deluge Valve, and all interconnecting piping must be located in a readily visible and accessible location and in an area that can be maintained at a minimum temperature of 40°F (4°C). Note: Heat tracing is not permitted. Pendent sprinklers, other than dry pendants, used on preaction systems shall be installed on return bends per NFPA 13.

System Air Pressure Requirements

A Rapidrop Model A-2 Pressure Maintenance Device is used to maintain the pneumatic pressure of both the Dry Pilot Line of detectors and the fire sprinklers to the values shown in Table A. The values listed in the table represent the necessary ranges of pneumatic pressure required to keep the Model LP Dry Pilot Line Actuator in the closed position for a given water supply pressure.

Water Pressure psi (bar)	Pneumatic Pressure to be Pumped into Sprinkler System psi (bar)	
	Not Les Than	Not More Than
20 (1.4)	8 (.6)	10 (.7)
30 (2.1)	10 (.7)	14 (1.)
50 (3.4)	12 (.8)	16 (1.1)
75 (5.2)	13 (.9)	17 (1.2)
100 (6.9)	15 (1.)	19 (1.3)
125 (8.6)	16 (1.1)	20 (1.4)
150 (10.3)	17 (1.2)	21 (1.4)
175 (12.1)	18 (1.2)	22 (1.5)
200 (13.8)	19 (1.3)	23 (1.6)
225 (15.5)	21 (1.4)	25 (1.7)
250 (17.2)	22 (1.5)	26 (1.8)

Note: During system set-up, a higher pneumatic pressure may be required in order to properly set the Model LP Dry Pilot Line Actuator.

Whenever multiple Preaction Systems are installed at the same location, it is strongly recommended that each system has its own Model A-2 Pressure Maintenance Device for individual maintenance of air pressure.

Dry Pilot Line Single Interlock Preaction System - Trim Engineering Specifications

General Description

Preaction system shall be a single interlock preaction system utilizing a [8" (200mm)] [cULus Listed] hydraulically operated, differential latch-type valve with pneumatic release preaction trim. Deluge valve shall be of lightweight, ductile-iron construction with "screw in" stainless steel seat and clapper assembly. Stainless steel seat shall have O- ring seals to resist leakage and corrosion. Clapper facing shall be pressure actuated, providing a limited compression seat for the sealing force between the clapper rubber facing and the valve seat. Deluge valve shall have an external reset knob for resetting the clapper without requiring the removal of the valve face plate. Push-rod chamber design shall consist of a stainless steel piston/ push-rod and spring assembly with diaphragm seal secured to the casting through a push-rod guide constructed of a synthetic engineering plastic to resist corrosion. Casting shall have a bleeder hole located on the push rod chamber for air/water leakage indication. Trip ratio shall be approximately a 3: 1 force differential. Deluge valve shall be of the straight through design to minimize friction loss, and be capable of being reset without having to remove the valve cover plate through the use of an external reset knob. In-let restriction orifice shall be factory installed into the inlet port of the deluge valve push-rod cover plate and not be a separate part of the deluge valve trim. End connection style to be [8" (200 mm)] grooved inlet and grooved outlet, per ANSI/ AWWA C606. Deluge valve shall have a rated working pressure of 250 psi (17,2 bar) and shall be factory hydrostatic tested at 500 psi (34,5 bar). Deluge valve to be [8" (200 mm)] Rapidrop Model DDX Deluge Valve (Bulletin 515).

Valve trim shall be Dry Pilot Line Single Interlock Preaction consisting of the following components:

- Hydraulic trim shall be galvanized and brass components specifically Listed/Approved with the deluge valve, including an emergency release valve and 2" main drain. Deluge valve's releasing device shall be a low-pressure pneumatic actuator.
- The low-pressure, pneumatic actuator shall be of cast iron construction utilizing a diaphragm and compression spring design to separate the push-rod chamber water pressure from the system piping's pneumatic supervisory pressure. The low-pressure actuator shall only require between 8 and 26 psi (0,6 to 1,8 bar) supervisory pressure for proper setting in accordance with the manufacturer's instructions. Lowpressure pneumatic actuator shall be Rapidrop Model LP Pilot Line Actuator.
- The low air pressure switch to indicate loss of air pressure in system piping shall be [cULus Listed] and of the bellowsactivated type enclosed in a weatherproof, 4x, NEMA 4-rated enclosure incorporating tamper-resistant screws. There shall be two sets of SPDT (form C) contacts rated 10.0 A @ 125/250 VAC and 2.5 A @ 6/12/24 VDC. The pressure switch shall have a maximum service pressure rating of 250 psi (17,2bar). Switch shall be provided with a 1/2" NPT male pressure connection. Low air supervisory switch shall be System Sensor EPS40-2.

Single Interlock Preaction System shall be a Rapidrop Dry Pilot Line Single Interlock Preaction System, Bulletin 742.



Dry Pilot Line Single Interlock Preaction System 8' (200 mm) Size

Pneumatic Supervisory Pressure Supply Options

Owner's Air supply

Supervisory air supply shall be provided by an owner supplied air system in conjunction with a [cULus Listed] automatic pressure maintenance device, capable of maintaining a constant system pressure regardless of pressure fluctuations in the compressed air source. The pressure maintenance device shall consist of galvanized trim and brass parts, including a strainer and a field adjustable air pressure regulator, and have a working pressure rating of 175 psi (12,1 bar). The pressure regulator shall have an adjustable outlet pressure range of 5 to 50 psi (0,34 to 3,4 bar). Pressure maintenance device shall be Rapidrop Model A-2 (see NFPA 13).

Compressed Air Supply

Supervisory air supply shall be provided by an automatic tank-mounted air compressor sized for the capacity (volume) of the single interlock preaction system piping, and be capable of restoring normal air pressure in the system within 30 minutes. Single interlock preaction system shall only require between 8 and 26 psi (0,6 to 1,8 bar) supervisory pressure for proper setting of the low pressure pneumatic actuator in accordance with the manufacturer's instructions. Air supply shall be equipped with an automatic pressure maintenance device capable of maintaining a constant system pressure regardless of pressure fluctuations in the compressed air (or nitrogen) source, or system piping. The pressure maintenance device shall consist of galvanized trim and brass parts, including a strainer and a field adjustable air pressure regulator, and have a working pressure rating of 175 psi (12,1 bar). The pressure regulator shall have an adjustable outlet pressure range of 5 to 50 psi (0,34 to 3,4 bar). Pressure maintenance device shall be Rapidrop Model A-2.

Nitrogen

Nitrogen cylinders provided by an approved source shall provide the nitrogen supply. Single interlock preaction system shall only require between 8 and 26 psi (0,6 to 1,8 bar) supervisory pressure for proper setting of the low pressure pneumatic actuator in accordance with the manufacturer's instructions. The nitrogen cylinder pressure shall be regulated and supervised through the use of nitrogen regulating device and low-pressure trim kit. This device shall consist of a brass, single stage pressure regulator, equipped with high pressure inlet and low pressure outlet gauges, and 1/2" copper connection tubing with galvanized 1/2" x 1/2" reducer bushing. Optional: Low-pressure trim kit shall be included to monitor the regulated nitrogen supply pressure to provide a low-pressure supervisory alarm. This kit shall include a low-pressure switch with associated galvanized connection trim. Assembly shall be a Rapidrop Nitrogen Regulating Device. This device is to be used in conjunction with the Rapidrop Model A-2 Pressure

Maintenance Device.

Optional System Accessories

System Control Valve

Preaction system control valve shall be a slow close, [cULus Listed] indicating butterfly type valve with a prewired supervisory tamper switch assembly. The valve shall be rated for a working pressure of [300 psi (20,7 bar)]. System control valve shall be for an [8" (200mm)]- Rapidrop Butterfly Valve.

Waterflow Alarm Pressure Switch

Alarm pressure switch shall be provided to indicate water flow and provide a water flow alarm. Pressure switch shall be [cULus Listed] and of the bellows activated type enclosed in a weatherproof, 4x, NEMA 4-rated enclosure incorporating tamper-resistant screws. There shall be two sets of SPDT (Form C) contacts rated at 10.0 A @125/250 VAC and 2.5 A @ 6/12/24 VDC. The pressure switch shall have a maximum service pressure rating of 250 psi (17,2 bar) and shall be factory adjusted to operate at a pressure of 4 to 8 psi (0,27 to 0,55 bar) with adjustment up to 20psi (1,3 bar). Switch shall be provided with a 1/2" NPT male pressure connection. Waterflow alarm pressure switch shall be System Sensor EPS1 0-2.

Technical Data

Rapidrop Wet Pilot Line Single Interlock Preaction Systems, with associated trim, size 8" (200mm) is rated for use at minimum water supply pressure of 20 psi (1,4 bar) and maximum supply pressure of 250 psi (17,2 bar). Water supplied to the inlet of the valve and to the pushrod chamber must be maintained between 40°F (4°C) and 140°F (60°C). The following list of technical bulletins pertains to valves and devices that may be used in this preaction system:

Deluge Valve	Rapidrop 514/515
Hydraulic Emergency Station (Model A)	Rapidrop 506
Mechanical Sprinkler Alarm	Rapidrop 612/613
Pressure Maintenance Device	Rapidrop 250/251
Fire Alarm Devices	Rapidrop 700
Waterflow/Low Air Pressure Alarm	Switch System Sensor
A05-0176	OPQRSTUVWXYZ
Nitrogen Regulating Device	Rapidrop 253
Pilot Line Detector	Rapidrop 180
ABCDEFGHIJKLMN	OPQRSTUVWXYZ



Dry Pilot Line Single Interlock Preaction System 8' (200 mm) Size

Model DDX Valve Description

- Rated working pressure:
Valve & System - 250 psi (17.2 bar).
- Factory tested to a hydrostatic pressure of 500 psi (34,5 bar). (Valve only)
- End and trim connections:
 - ANSI/AWWA C606 grooved inlet and outlet

Groove Dimension			
Outlet Diameter	Groove Diameter	Groove Width	Outlet Face to Groove
8.625"	8.441"	7/16"	3/4"
(219mm)	(214mm)	(11mm)	(19mm)

- Threaded openings Per ANSI B 2.1
 - Valve Exterior's Color: Black
- Face to face dimensions:
 - 19 3/8" (492mm)
 - Shipping weight:
 - 148 lbs (67.3 kg)
 - Friction loss (Expressed in equivalent length of Schedule 40 pipe, based on Hazen & Williams formula with C= 120)
 - 53.5ft (16.31 m)
 - Installation position: Vertical

Maintenance

Rapidrop Dry Pilot Line Single Interlock Preaction Systems and associated equipment shall periodically be given a thorough inspection and test. NFPA 25, Inspection, Testing and Maintenance of Water Based Fire Protection Systems, provides minimum maintenance requirements. System components shall be tested, operated, cleaned, and inspected at least annually, and parts replaced as required.

Resetting the Single Interlock Preaction System

Refer to Figs. 2, 4, and 5.

- Close the main valve controlling water supply (Fig. 5) to the Deluge Valve and close off the air supply to the sprinkler system.
- Close the pushrod chamber supply valve; valve A (Fig. 5).
- Open the main drain valve, valve B (Fig. 5), and drain system.
- Open all drain valves and vents at low points throughout the system, closing them when flow of water has stopped. Open valve D (Fig. 5). Note: The above steps accomplish the relieving of pressure in the push rod chamber of the Deluge Valve.

- With valve F (Fig. 5) open, push in the plunger of ball drip valve, valve G (Fig. 5), to force the ball from its seat, and drain any water in the alarm line.
- With the Model B Manual Emergency Station, valve D (Fig. 5), open, push in and rotate the Deluge Valve's external reset knob (#14, Fig. 4) clockwise until you hear a distinct clicking noise, indicating that the clapper has closed. Note: The reset knob can be rotated only while pressure in the pushrod chamber is vented to atmospheric conditions (0 psig).
- Inspect and replace any portion of the sprinkler system subjected to fire conditions.
- Open valve A (Fig. 5) and allow water to fill the Deluge Valve's pushrod chamber. Close valve D (Fig. 5).
- Bleed any air from the actuation piping. Open valve D (Fig. 5) allowing water to flow through the pilot line actuator. Close valve F (Fig. 5). When all air has been expelled from the release line, and there is a solid flow of water into the drain cup H (Fig. 5), apply compressed air or nitrogen through the pressure maintenance device to close the pilot line actuator. Note: It may be necessary to temporarily close the main drain valve B (Fig. 5) in order to build sufficient air pressure to "set up" the Model LP Actuator. Once the Model LP Actuator is "set up", the main drain valve B (Fig. 5) should be reopened and the remaining procedure followed. Subsequently, close valve D (Fig. 5) and adjust the air or nitrogen pressure to the appropriate value in Table A as indicated on air pressure gauge (#22, Fig. 2).
- Open valve F (Fig. 5). Open slightly the main valve controlling water supply (Fig. 5) to the Model DDX Deluge Valve, closing drain valve B (Fig. 5) when water flows. Observe if water leaks through the ball drip valve, G (Fig. 5), into the drip cup H (Fig. 5). If no leak occurs, the Deluge Valve's clapper is sealed. Open slowly, and verify that the main valve controlling water supply is fully opened and properly monitored
- Verify that valve A (Fig. 5) and valve F (Fig. 5) are open.
- Secure the handle of the Model B Manual Emergency Station, valve D (Fig. 5), in the OFF position with a nylon tie (#59, Fig. 2)

Dry Pilot Line Single Interlock Preaction System 8' (200 mm) Size

Model DDX 8" (200mm) Deluge Valves Parts List (Refer to Fig. 4)

MODEL DDX VALVE 8"(200MM)

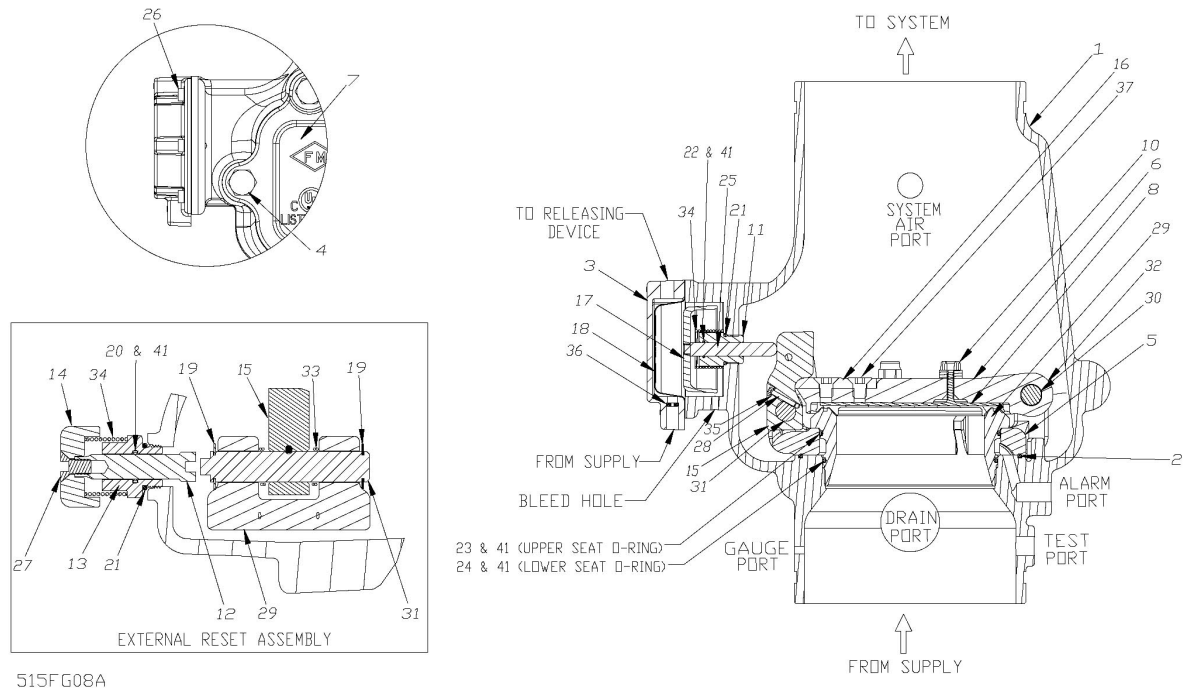

Item No.	Part Number	Part Description	No. Req'd
1	91006028	Body	1
2	95406414	O-Ring, (266)	1
3	92126006	Cover, Pushrod	1
4	95606110	Screw, Hex Cap, 5/8-11 x 2", ZN PLTD, Grade A	8
5	91306018	Mounting Ring	1
6	91916008	Clapper	1
7	92116068	Cover, Access	1
8	93416008	Seal Assembly	1
9	93706008	Gasket, Access Cover (Not Shown)	1
10	93722000	Bumpstop Assembly	3
11	93916006	Pushrod Guide	1
12	93916066	Shaft, Reset	1
13	94106066	Housing, Reset	1
14	94356006	Knob, Reset	1
15	94506008	Lever	1
16	95006410	Striker, Lever/Clapper	1
17	95106006	Piston	1
18	95276006	Diaphragm	1
19	95316408	Clip, Retaining, 3/4" Shaft, SS	4
20	95406007	O-Ring, (114)	1
21	95406024	O-Ring, (912)	2
22	95406407	O-Ring, (014)	1

Item No.	Part Number	Part Description	No. Req'd
23	95406413	O-Ring, (260)	1
24	95406412	O-Ring, (259)	1
25	95506006	Pushrod	1
26	95606114	Screw, Socket Head, 1/2-20 x 5/8"	6
27	95606127	Screw, Socket Cap, Flat Head, 3/8-16 x 3/4"	1
28	95606130	Screw, Socket Head, #10-23 x 1", SS	1
29	96016008	Seat	1
30	96206008	Pin, Hinge	1
31	96216008	Pin, Lever	1
32	96310008	Spacer, Clapper	2
33	96406008	Spring, Lever	1
34	96406906	Spring, DDX	2
35	96906111	Washer, Spring Lock, #10, SS	1
36	94206406	Inlet Orifice	1
37	95606135	Screw, Socket Cap, Flat Head, 1/2-13 x 3/4", SS	2
38	94616921	Label, Caution, Knob (Not Shown)	1
39	91556922	Ball Chain, 1/8" (Not Shown) (Length in inches)	6
40	91556923	Clamping Link, Ball Chain, (Not Shown)	1
41	85000050	O-ring Grease, DuPont™ Krytox® GPL-201	A/R



Dry Pilot Line Single Interlock Preaction System 8' (200 mm) Size

Inspection and Testing

Refer to Figs. 2, 4, and 5.

1. **Water supply** - be sure the valve(s) controlling water supply to the Deluge Valve are opened fully and properly monitored.
2. **Alarm line** - be sure that valve F (Fig. 5) is opened and remains in this position.
3. **Other trimming valves** - check that valve A (Fig. 5) is open as well as all of the pressure gauge's 1/4" 3-way valves. Valves D, E, and F (Fig. 5) should be closed.
4. **Ball drip valve G (Fig. 5)** - make sure that valve F (Fig. 5) is open. Push in on the plunger to be sure the ball check is off its seat. If no water appears, the Deluge Valve's water seat is tight. Inspect the bleed hole (see Fig. 4) in the side of the push rod chamber for leakage.
5. **System pneumatic pressure** - check that system air pressure corresponds to the values found in table A. Check the pressure maintenance device for leakage and proper pressure.
6. **Releasing device** - check outlet of the releasing device (i.e., Model LP Dry Pilot Line Actuator or the Model B Manual Emergency Station, valve D (Fig. 5) for leakage. Also verify that tubing drain lines from releasing devices are not pinched or crushed which could prevent proper releasing of the Deluge Valve.
7. **Testing alarms** - make sure that valve F (Fig. 5) is open. Open valve J (Fig. 5) permitting water from the supply to flow to the electric sprinkler alarm switch and to the mechanical sprinkler alarm (water motor). After testing, close this valve securely. Push in on the plunger of ball drip valve G (Fig. 5) until all of the water has drained from the alarm line.
8. **Operational test** - Open the Model B Manual Emergency Station, valve D (Fig. 5). Note: An operational test will cause the Deluge Valve to open and flow water into the sprinkler system.
9. Secure Model B Manual Emergency Station, valve D (Fig. 5), in the OFF position with a nylon tie (#59, Fig. 2) after the Deluge Valve is reset.

Testing the Model DDX Deluge Valve Without Flowing Water

Refer to Fig. 6

1. Close the main valve controlling water supply to the Deluge Valve.
2. Verify that valve A is open, allowing water to enter the push rod chamber.
3. Close off the air/nitrogen supply to the sprinkler system and the Dry Pilot Line.
4. Decrease pneumatic pressure in the system by opening the 1/4" globe valve, valve E, until the Model LP Dry Pilot Line Actuator operates. This will be indicated by a sudden drop of water pressure on the Deluge Valve's gauges. The operation of the Actuator will vent the push-rod chamber of the Deluge Valve and cause the Valve's clapper to open.

5. To reset the system, close the 1/4" globe valve, valve E, and proceed according to the directions listed in the "Resetting the Single Interlock Preaction System" section of this bulletin.

Draining Excess/Condensate Water From System

Refer to Fig. 6

1. Close the main valve controlling water supply to Deluge Valve. Also close valve A and open main drain valve B.
2. Open condensate drain valve E until all water has drained. Close valve E. Note: Be sure not to keep valve E open for an extended period of time because that will cause enough system air to bleed off thereby causing an undesirable activation of a trouble-annunciating device.
3. Close main drain valve B. If system contains pressurized air, allow air pressure to come back up to specification. Open valve A first, and then open the main valve controlling the water supply to the Deluge Valve.

Maintenance Procedures - Model DDX Deluge Valve

Refer to Figs. 2, 4, & 5.

1. Mechanical sprinkler alarm (water motor-not shown) not operating:

This is most likely caused by a clogged screen in the strainer of the water motor. Proceed as follows: Remove plug from the strainer. Remove and clean the screen. Replace the screen and the plug, and then tighten securely (Ref. Bulletin 613).

2. Leakage out of the ball drip valve G (Fig. 5).

a. Water leakage due to a water column above the Deluge Valve's clapper: This condition can be caused by leakage past the system side of the Model DDX Deluge Valve's seal assembly (#8, Fig. 4). Be sure that this surface is free of any type of debris. To eliminate leakage due to a water column, refer to the section in this bulletin marked "Draining Excess/Condensate Water From System". If the problem continues proceed to the following section.

b. Leakage, air or water from the ball drip valve, G (Fig. 5): If system air is leaking out the ball drip valve, the problem is either damage to the airside of the Model DDX Deluge Valve's seal assembly (#8, Fig. 4), seat (#29, Fig. 4) mounting ring O-ring (#2, Fig. 4), or the upper seat O-ring (#23, Fig. 4). If supply water is leaking out the ball drip valve, the problem could be caused by damage to the Model DDX Deluge Valve's seal assembly (#8, Fig. 4), seat (#29, Fig. 4), or lower seat O-ring (#24, Fig. 4). The following section provides instructions to correct both conditions:

Dry Pilot Line
Single Interlock Preaction System
8' (200 mm) Size

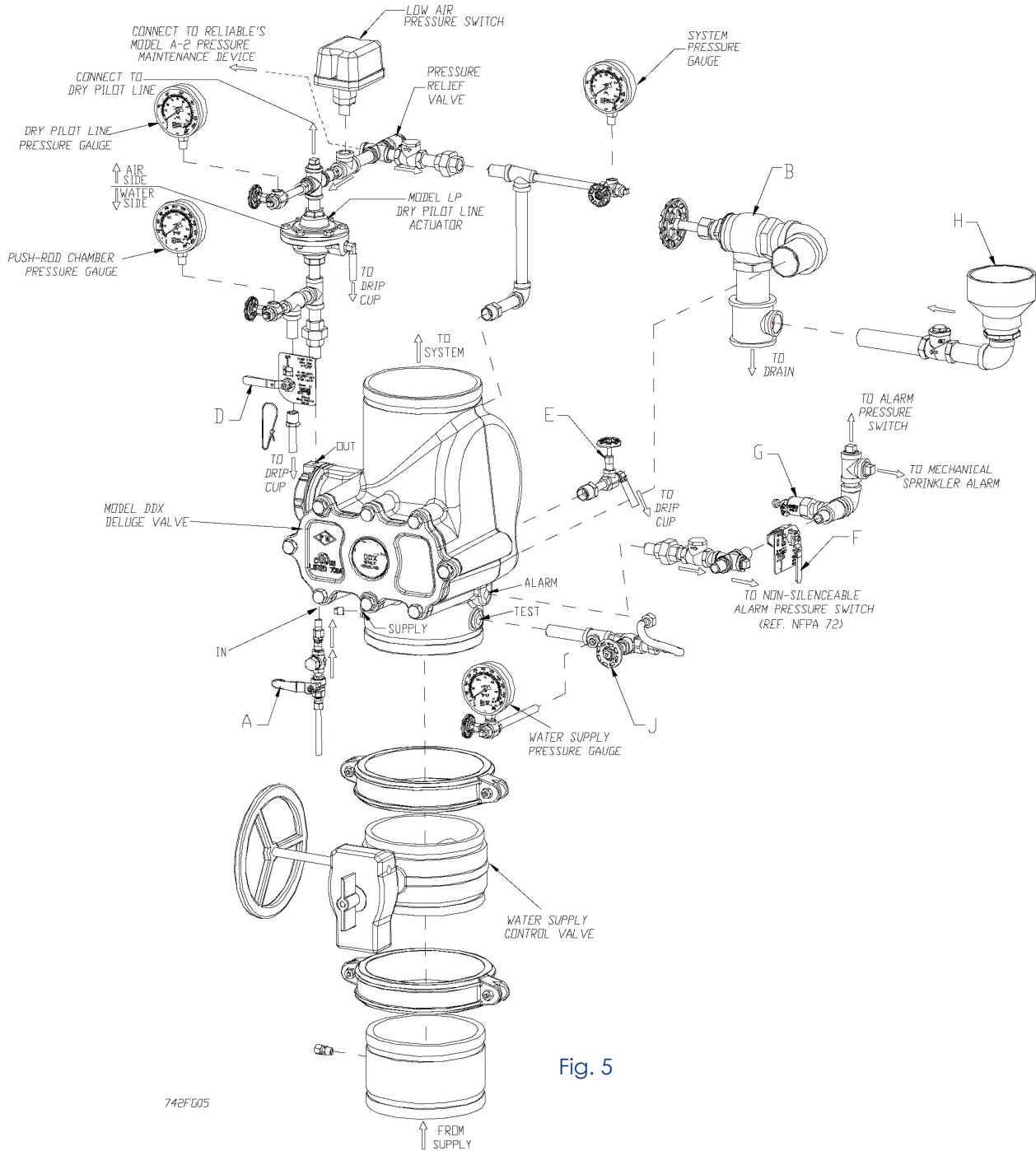



Dry Pilot Line Single Interlock Preaction System 8' (200 mm) Size

- A. Shut down the valve controlling the water supply to the Deluge Valve and open the 2" main drain valve B (Fig. 5). Open the water column drain valve E (Fig. 5). Close the push rod chamber supply valve A (Fig. 5) and open the Model B Manual Emergency Station D (Fig. 5).
- B. Remove the Deluge Valve's front (handhold) cover (#7, Fig. 4) and inspect the seat (#29, Fig. 4), clapper (#6, Fig. 4), and seal assembly (#8, Fig. 4) for damage.

If inspection indicates damage to the seal assembly (#8, Fig. 4), replace as follows:

Remove the bumpstop nuts (#10, Fig. 4) and remove the seal assembly (#8, Fig. 4). Install a new seal assembly (#8, Fig. 4) and thread the bumpstop nuts (#10, Fig. 4) onto the threaded stud of the seal assembly (#8, Fig. 4) and tighten finger tight plus ¼ to ½ turn.

If inspection indicates damage to the clapper (#6, Fig. 8) only, then the clapper sub-assembly can be removed as follows: At the rear of the valve, disconnect the water column drain trim section starting with the elbow connector (#14, Fig. 2). Then remove the ¼" globe valve (#24, Fig. 2), followed by the ¾"x¼" reducing bushing (#9, Fig. 2). Remove the retaining ring (water column drain line side) from the clapper hinge pin (#30, Fig. 4) and push this pin through handhold cover and remove the clapper subassembly. Replace the seal assembly as described previously. Inspect the clapper (#6, Fig. 4) visually before reinstalling. Reinstall in the reverse order making sure the clapper spacers are in their proper position. If the seat (#29, Fig. 4) is damaged or it is suspected that the leakage is through the lower O-ring (#24, Fig. 4), the seat-clapper subassembly is easily removed as a unit as follows:

Using Rapidrop PIN 6881608000 Seat Wrench, re-move the seat by unscrewing. This will loosen the seat-clapper-mounting ring sub-assembly. Reach into the valve and grasp the seat and remove it from the valve. Then remove the clapper-mounting ring assembly from the valve. Visually examine all components of the seat-clapper-mounting ring sub-assembly replacing any component that appears damaged. New O-rings (#2, #23 & #24, Fig. 4) should always be used for reassembly.

Reassembly:

Clean the bore of the valve body. Lubricate the bore with O-ring grease. Lubricate and install the O-rings (#23 & #24, Fig. 4) onto the seat (#29, Fig. 4) and O-ring (#2, Fig. 4) into the body (#1, Fig. 4). Insert the clapper-mounting ring sub-assembly into the handhold opening of the Deluge Valve. Align the mounting ring so that the Lever (#15, Fig. 4) is near the pushrod (#25, Fig. 4) and the mounting ring (#5, Fig. 4) "ears" are between the tabs of the valve body (#1, Fig. 4). Insert the seat (#29, Fig. 4) into the valve body (#1, Fig. 4) and through the clapper-mounting ring assembly. Start to tread the seat (#29, Fig. 4) into the body by hand, then tighten the seat (#29, Fig. 4), with seat wrench 6881608000, until it bottoms out on the mounting ring (#5, Fig. 4). Verify that the seat-clapper-mounting ring subassembly is in the fully down position between the tabs of the body, and check to see that the lever (#15, Fig. 4) lines up with the push rod (#25,

Fig. 4). Loosen and reassemble if necessary. Reassemble the handhold cover (#7, Fig. 4) and set up the Model DDX Deluge Valve as per the section "Resetting Model DDX Deluge Valve Systems."

3. Leakage out of the push rod chamber vent hole:

A small bleed hole is located on the underside of the push rod chamber (see Fig. 4). If there is air or water leakage coming out of this hole, do the following:

- a. Shut down the valve controlling water supply to the Deluge Valve. Relieve the inlet pressure by opening the 2" drain valve B (Fig. 5). Close the valve A (Fig. 5) that supplies water to the push rod chamber, and open the Model B Manual Emergency Station, valve D (Fig. 5).
- b. Remove the trim at the unions nearest to the pushrod chamber cover (#3, Fig. 4).
- c. Take the push rod chamber cover (#3, Fig. 4) off by removing the six retaining screws (#26, Fig. 4).

CONDITION ONE (Water coming out of the bleed hole):

Water coming out of the bleed hole is caused by a leaking diaphragm (#18, Fig. 4). Visually inspect the push rod chamber cover (#3, Fig. 4) and piston (#17, Fig. 4) to determine what could have damaged the diaphragm and correct. Install a new diaphragm. NOTE: The diaphragm has two different surfaces. It is not bi-directional. It will fail if installed backwards! Roll the diaphragm so that the smooth surface (the pressure side) conforms to the inside of the push rod chamber cover and reassemble the six retaining screws (#26, Fig. 4) with an installation torque of 15 foot-pounds. Set up the Model DDX Deluge Valve as per the section "Resetting the Single Interlock Preaction System".

CONDITION TWO (System Air coming out of the bleed hole):

System air coming out of the bleed hole is caused by a defective O-ring assembled to the pushrod guide (#11, Fig. 4). Remove the piston-push rod subassembly, push rod spring (#34, Fig. 4), and push rod guide (#11, Fig. 4). Verify by hand turning, that the push rod cannot be unscrewed from the piston. Replace all O-rings and the push rod guide (#21 & #22, Fig. 4). The correct installation torque for the push rod guide is 35 inch-pounds. CAUTION: Do not over tighten the pushrod guide. Reassemble the components that were initially removed. Reinstall the diaphragm (#18, Fig. 4) if it appears to be in good shape, otherwise, replace it also. NOTE: The diaphragm has two different surfaces. It is not bi-directional. It will fail if installed backwards! Roll the diaphragm so that the smooth surface (the pressure side) conforms to the inside of the push rod chamber cover and reassemble the six retaining screws (#26, Fig. 4) with an installation torque of 15 foot-pounds. Set up the Model DDX Deluge Valve as per the section "Resetting the Single Interlock Preaction System".

Dry Pilot Line
Single Interlock Preaction System
8' (200 mm) Size

MODEL LP DRY PILOT LINE ACTUATOR

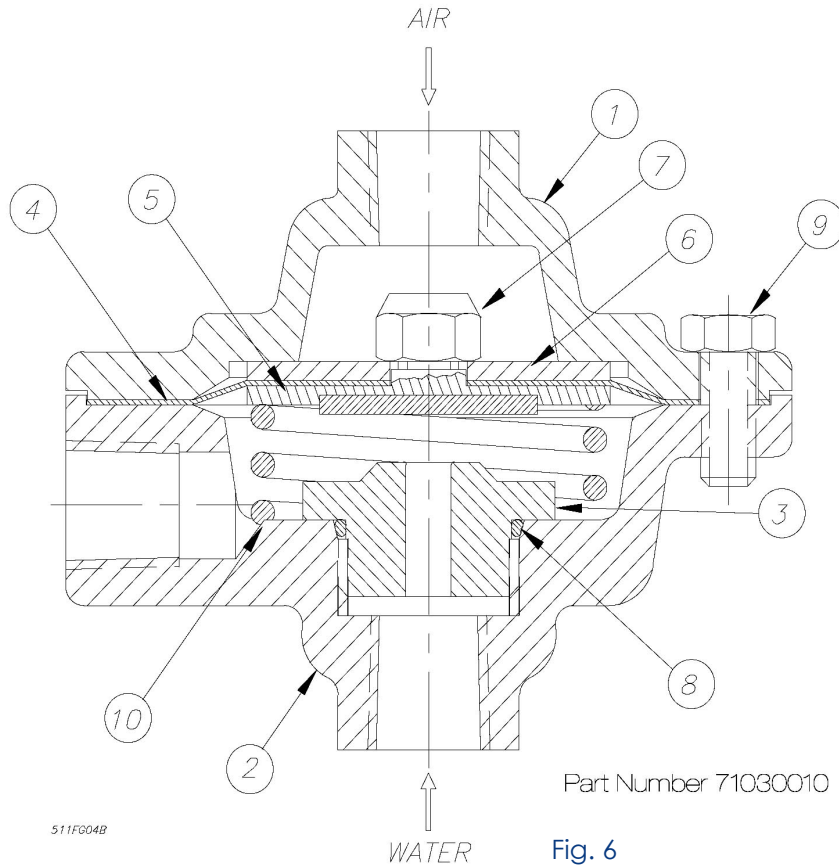

Fig. 6

Model LP Dry Pilot Line Actuator Parts list P/N 71030010

Item No.	Part No.	Description	Qty. Required
1	94106936	Lower Housing	1
2	94106935	Upper Housing	1
3	96006905	Seat	1
4	92206311	Diaphragm	1
5	95106911	Facing Plate Assembly	1
6	96906311	Diaphragm Washer	1
7	94906406	Facing Plate Nut	1
8	95406901	Seat O-Ring	1
9	95606305	Bolt	6
10	96406902	Compression Spring	1

Maintenance – Model LP Dry Valve Actuator

Refer to Figs. 6 and 7

If water constantly flows through the Model LP Dry Valve Actuator and into the drain, there is a leak in the seal of the Actuator's seat.

1. Close the main valve controlling water supply (Fig. 6) to the Dry Pipe Valve and close off the air/nitrogen supply to the sprinkler system. Close valve A (Fig. 6).
2. Drop pressure in the system by opening the 1/4" globe valve, valve E (Fig. 6.), and remove the Actuator from the system.
3. Remove all six bolts (#9, Fig. 7) holding the Actuator together. Clean or replace the facing plate assembly (#5, Fig. 7) and seat (#3, Fig. 7).
4. Reassemble the Actuator, using a torque of 8 ft-lbs on the facing plate nut (#7, Fig. 7) and 12 ft-lbs on the six bolts (#9, Fig. 7). Use a cross-tightening pattern. Reinstall the Actuator. Set up the Model DDX-LP Dry Pipe Valve as per the section "Resetting Model DDX-LP Dry Pipe Valve System."



Dry Pilot Line Single Interlock Preaction System 8' (200 mm) Size

Ordering Information:

Specify:

- **Valve Model & Size** — 8" (200 mm) Model DDX Deluge Valve (P/N 6103080001)
- **Trim** – The trim set is available in individual parts, in time-saving segmentally assembled kit forms, or fully assembled to the Model DDX Deluge Valve with or without a control valve.
- **Low Air Pressure Switch** – UL/FM Approved (System Sensor Model EPS10-2) or ULC Listed (System Sensor Model EPSA10-2).

	Trim Configurations	Trim Part Numbers
UL/FM Approved Pressure Switch	Fully Assembled to DDX Valve w/ Control Valve	6505080281
	Fully Assembled to DDX Valve w/o Control Valve	6505080280
	Segmentally Assembled (DDX Valve Sold Separately)	6503001733
	Individual Parts (DDX Valve Sold Separately)	6503001732
ULC Approved Pressure Switch	Fully Assembled to DDX Valve w/ Control Valve	6505080283
	Fully Assembled to DDX Valve w/o Control Valve	6505080282
	Segmentally Assembled (DDX Valve Sold Separately)	6503001735
	Individual Parts (DDX Valve Sold Separately)	6503001734

Note: For metric installations, a 2" NPT x R2. ISO 7/1 x Close Nipple (Rapidrop P/N 98543401) is sold separately as an adapter for the single drain outlet of the trims.

Component Part	Mfgr.	Description	Technical Bulletin
Water Supply Control Valve	Select	OS&Y, 8" (200 mm)	-
		Butterfly, 8" (200 mm)	-
Tamper Switch (Optional) for OS&Y Valve	B	Model OS&Y2	System Sensor A05-0196
Tamper Switch (Optional) for Butterfly Valve		Model P1BV2	System Sensor A05-0197
Deluge Valve	A	Model DDX 8" (200 mm)	514/515
Single Interlock Trim Kit	A	Refer to Parts in this Bulletin	742
Waterflow Alarm Pressure Switch	B	Model EPS10-2 (DPDT UL, FM)	System Sensor
		Model EPSA10-2 (DPDT ULC)	A05-0176
Low Air Alarm Pressure Switch	B	Model EPS40-2 (DPDT UL, FM)	System Sensor
		Model EPSA40-2 (DPDT ULC)	A05-0177
Mechanical Alarm (Optional)	A	Model C	612/613
Manual Emergency Station	A	Model A Hydraulic (Pilot Line) Type	506
Pilot Line Detector/Sprinkler	A	Model F1-FTR	180
Sprinklers	A	Closed Type	110, 117, 131, 136, etc.
Air Compressor	C	Tank Mounted	Gast H-10-0801
Pressure Maintenance Device	A	Model	A-2 250/251
Nitrogen Regulating Device	A	Regulator with Optional Low Air Pressure Switch	253

System Equipment Manufacturers

- (A) Rapidrop
- (B) System Sensor
- (C) Gast Manufacturing Corp.

Dry Pilot Line
Single Interlock Preaction System
8' (200 mm) Size

DRY PILOT LINE SINGLE INTERLOCK PREACTION SYSTEM COMPONENTS

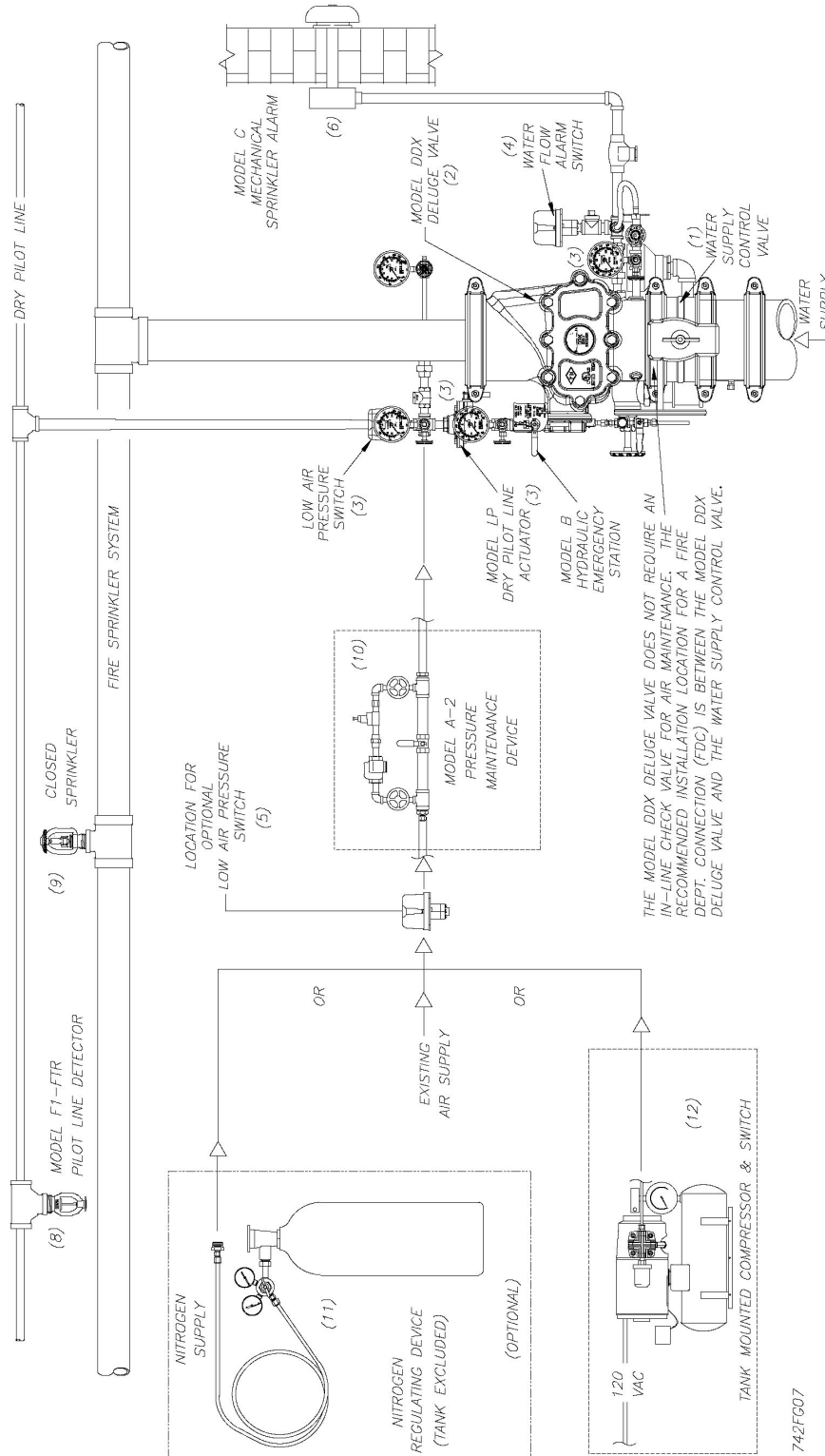



Dry Pilot Line
Single Interlock Preaction System
8' (200 mm) Size

Installation Dimensions

A	B	C	*D	E	F	G	H	J	K	L	M	N	P	Q
7 1/4	9	11 1/4	19 3/8	31	25	8 1/2	9	9	5 1/2	8 1/1	15	2 3/4	4 1/4	13
(184)	(229)	(286)	(492)	(787)	(635)	(216)	(229)	(229)	(140)	(216)	(381)	(70)	(114)	(330)

